



SELF STUDY REPORT

FOR

4th CYCLE OF ACCREDITATION

JAMIA HAMDARD (HAMDARD UNIVERSITY)

MEHRAULI BADARPUR ROAD, HAMDARD NAGAR

110062

www.jamiahamdard.edu

Submitted To

NATIONAL ASSESSMENT AND ACCREDITATION COUNCIL

BANGALORE

September 2022

1. EXECUTIVE SUMMARY

1.1 INTRODUCTION



Jamia Hamdard was the first higher education institution (HEI) in the national capital region (NCR) which was accredited by the NAAC accreditation in 2003, thus testifying the quality consciousness of the then leadership of the institution. It has been ranked in 'A' grade in all the three cycles and now presents for the 4th cycle. To our understanding, there are only few HEI which have come thus far in the quest for the quality. Its accreditation status is matched by the ranking in the National Institutional Framework Ranking (NIRF). It has the distinction of being ranked No. 1 in 'Pharmacy' category for four consecutive cycles (NIRF2019-2022). Not only NIRF, for last many years Jamia Hamdard has also been ranked by the international rankings such as QS and THE. In the Report of the Committee for Review of Existing Institutions Deemed to be Universities (2009) constituted by the Ministry of Human Resource Development (now - Ministry of Education) placed Jamia Hamdard in Table I listing 38 Deemed Universities out of 129 justifying their continuation as "deemed universities". In the year 2019 it was included in the list of HEI for consideration of Institute of Eminence by the Empowered Expert Committee constituted by the Government. The ranking and accreditation is a result of sustained efforts of the leadership in the area of faculty and student quality. University offers contemporary and innovative programmes of studies from diploma to doctoral levels with an academic flexibility. There is also a thriving post-doctoral researcher community. Jamia Hamdard is open to all for career and professional development. The research profile (publications and citations) is impressive and it has paid dividends with award of DST-PURSE and STUTI Schemes primarily based on quality of publications, citations and h-index. The University provides an inimitable milieu for the holistic development of the students and upholds all the functional integrities of an institution of excellence. The accreditation and rankings and laudable transformation in its overall performance are endorsements for quality of education imparted by the University. In this SSR we have made an attempt to present the various facets of Jamia Hamdard encompassing NAAC performance indicators.



Vision

“To provide international standard higher education and undertake progressive research in the fields of natural sciences, health-care, technology, social sciences and law;

To promote the study of modern and traditional, especially Unani, medicine systems with a holistic and integrative approach to healthcare and

To meet the societal education needs of underprivileged Indian communities.”

Mission

a) To promote and advance the cause of higher education through modern methods of teaching and advanced research in such branches of knowledge as the Jamia Hamdard may continue to develop core competence for and as may be in consonance with the emerging needs of India in general and underprivileged communities in particular.

b) To co-operate, collaborate and associate with national and international organizations and institutions in any part of the world having mission wholly or partly similar to those of the Jamia Hamdard and as per the provision of the UGC Regulations in place from time to time.

c) To provide avenues for higher education leading to excellence and innovations in such branches of knowledge as may be deemed fit primarily at Under-graduate, Post-graduate and doctoral/research degree levels, fully conforming to the concept and idea of the University as defined in the UGC Regulations 2019.

1.2 Strength, Weakness, Opportunity and Challenges(SWOC)

Institutional Strength

Infrastructure: Jamia Hamdard (Main campus) is located in the prime South Delhi area having a sprawling green campus of about 91.6 acres. It has ten schools including two medical schools, one each for modern medicine and Unani medicine. The campus at Kannur, Kerala has adequate infrastructure for academic activities.

Teaching and Research: Jamia Hamdard offers a wide range of study programmes – diploma to doctorate. Majority of programmes is of professional or technical nature. Teacher quality is ensured by a rigorous process of recruitment and promotion. Teachers are encouraged to obtain research and consultancy projects. Research is supplemented by an enabling research ecosystem, R&D Cell, intramural and extramural research funding. Other key features are - DSIR recognition, DST-PURSE and STUTI grants, AYUSH Ministry-Centre for Excellence, DST-FIST and UGC- SAP and MoU with reputed research institutions and industry.

Accreditation Rankings, and Regulatory Framework: Jamia Hamdard is accredited by NAAC in three cycles A grade in all cycles The institution has figured in major rankings such as NIRF, QS and THE. In NIRF under Pharmacy category it has ranked 1st in last four cycles – 2019 to 2022. In other categories in NIRF-2022 rankings are as follows – Medical – 33; Management – 100; University – 45; Overall – 73.

Student Diversity and Gender Equity: There is a rich diversity of students in terms of regional and community. This diversity is augmented by a large number of foreign students (more than 300). Almost 50% students are girls.

Rich Campus Life: Jamia Hamdard works for a holistic development of students. They are motivated to participate in social outreach programmes. The sports facilities are state-of-the-art. Various students' clubs cater to diverse interests of students - Yoga Club, Mental Health Club, Literary Club, Sports Club, Music Club, Film and Drama Club, Eco Club and Mountaineering Club. Professional student chapters of IEEE and ISTE, Girlsup Club, EPOCH Society and Rotract Jamia Hamdard enrich profile of students.

Green Initiatives: Jamia Hamdard has adopted various green initiatives - rainwater harvesting, solar energy harvesting, recycling of plastic waste and other biodegradable waste through composting, and recycling of waste water.

Institutional Weakness

In view of the mandate of Jamia Hamdard to cater to minority community students, who are economically disadvantaged, there is a limit to which fee may be increased. The regular funding by the government have decreased in both quantum and frequency. This has affected the financial health of the institution.

Jamia Hamdard has also not been able to secure major funding from non-governmental sources including industry. Although, in recent past alumni community has shown keen interest in the university affairs, financial contribution from alumni is still to catch up.

Due to introduction of skill-oriented curriculum, it has been observed that there is a need to hire skilled and technical staff. In addition, a systematic approach is needed to improve skills of existing staff to meet the challenges in the areas of pedagogy, office management skill and technical proficiency.

There are many job-oriented programmes in Jamia Hamdard. However, the culture of startups and entrepreneurship has not flourished well. Recently, Jamia Hamdard has established a Centre of Innovation Incubation & Entrepreneurship (CIIE) to promote entrepreneurship among faculty and students. It is hoped that this initiative will mitigate the stated weakness.

Institutional Opportunity

Locational advantage: Location in the NCR gives us opportunity to connect to the central and state governments and corporate sector. Exchange programs with national and international universities and research organizations can be undertaken, as we are located in India's Capital (Delhi). Jamia Hamdard has formulated a policy for the recruitment of foreign faculty. In view of locational advantage it is expected to attract foreign faculty to the campus.

Interdisciplinary studies: There is a vast scope of inter-disciplinary and multi-disciplinary teaching and research in Jamia Hamdard, as there is a unique blend of academic programmes and research in modern medicine and traditional medicine (Unani system) offering an opportunity of integrative platform. Besides, Schools offer novel programmes in disciplines of Food Technology, Molecular Medicine, Virology, Toxicology, International Studies, Governance, and Federal Studies demonstrate a diverse spectrum of opportunities available to students and faculty.

Research Ecosystem: There is a fully functional Research and Development Cell (RDC) as per UGC guidelines. Well-developed sophisticated instrumentation facilities can be used for providing hands-on skill training and development. There are ample opportunities for translational research, collaborative industry-academia research. In this line, the University has created a Centre for Innovation, Incubation and Entrepreneurship (CIIE), which will provide value-added and skill based short term courses that will increase the employability of students.

Sectorial Opportunities: More sectorial specializations in line with market requirements can be started, since Jamia Hamdard has excellent infrastructure and has maintained standards in teaching and research, as evident from the placement records, high quality research grants, publications, citations and patents. The Centre for Training and Development provides opportunity for professional development of students.

Outreach activities: The spirit of service (*Hamdard*) is the core strength of Jamia Hamdard. Since its inception it has taken up social causes seriously. Our founder, Hakeem Abdul Hameed has left a legacy of social service. Five villages have been adopted under *Unnat Bharat Abhiyan* and efforts are on to add more. Various community outreach activities such as, health camps, free vaccination drives, tree plantation and free legal aid camps provide an opportunity for service to the society and inclusiveness of various stakeholders.

Institutional Challenge

One of the challenges in a university system is to keep pace with ever-changing pedagogy, technology and technological media to reach out to students. Jamia Hamdard is no exception to this challenge. The digital space and digital platforms have become an important conduit for attracting students. Our university is trying to keep pace with this digital revolution.

Jamia Hamdard, by virtue of its location in Delhi is in much demand in terms of admission. With the 1st ranking in NIRF in the Pharmacy category for the last four years, NMC-recognized Medical School with 33rd ranking in NIRF-2022 and 100th ranking in Management in NIRF-2022 aspiring students and their parents are seeking admission in Jamia Hamdard from all corners of India and also from abroad. In order to meet the surging demand for admission, Jamia Hamdard finds itself in a position of deficiency of space for further expansion of academic and residential (hostel) infrastructure. Sustaining ranking is also a challenge, as the number of participating institutions in the ranking framework is increasing every year.

The other challenge being faced is the inadequacy of funds for more infrastructural development and better maintenance.

The decline in enrollment due to COVID-19 pandemic poses a real financial challenge which may compromise the research infrastructure and its maintenance.

Non-availability of appropriate skilled and technical human resources is also a challenge for research-oriented institutions like Jamia Hamdard.

1.3 CRITERIA WISE SUMMARY

Curricular Aspects

Jamia Hamdard has designed the holistic curriculum that focuses on upholding the rich traditional values and at the same time incorporating the recent advances & technology. Jamia Hamdard has implemented The National Education Policy-2020 notified by the Government of India in phased manner with comprehensive strategic plan. Regular Academic Council and Board of Studies meetings critically analyze the relevance of the programme for meeting the changes in the community, hospitals and industry with inputs received from stakeholders in industry, nationally reputed institutions, research organizations, alumni, faculty and students. Structured POs, COs and CLOs are formulated and practiced for the programs as a quality indicator for Outcome Based Education to meet the global needs. For implementation of the outcome-based education within the framework of Choice Based Credit System pattern, Centre for Teaching Support and Innovations has been started through regular monitoring and advising on teaching and learning aspects.

Courses offered by Jamia Hamdard emphasize on inclusiveness and all round development of students paying special attention to professional ethics, gender, human values, environment and sustainability in accordance with the rules given by regulatory bodies. Integration of such courses gives a conducive environment for advancement of students' identity within his/her journey, to inculcate justice, harmony, peace, societal connect, sense of responsibility and commitment.

Sense of Community service is inculcated student's participation in Unnat Bharat Abhiyan from year 2019, by adopting 5 villages with successful implementation of various community based projects. Jamia Hamdard has Internal Complaint Committee (ICC), Equal Opportunity Cell and Women's Grievances Redressal Cell in place to address grievances, issues of sexual harassment. Environment club and Environmental Quality Cell (EQC) are committed to minimize the negative environmental impact not only in Jamia Hamdard but its neighborhood.

Teaching-learning and Evaluation

Jamia Hamdard offers graduate, postgraduate and doctoral programmes in several disciplines for which adequate facilities are available. University focuses on imparting equitable education to learners from different socio-economic-cultural background with varying learning abilities. The university assesses the slow and fast learners through various assessment techniques and train them according to their area of interest to enrich and strengthen the subject-specific domains. Jamia Hamdard is well endowed with intellectual capital and adequate number of faculty members as evident by student- teacher ratio who have expertise in various field required for student development and training according to global demands. A number of faculty members are PhD, known for excellence in cutting-edge research in various fields both nationally and internationally. The University focuses and uses student centred approaches such as project works, internship, Innovation and Incubation centres, hands-on training to improve learning and problems solving abilities in students.

Jamia Hamdard envisages to adapt to changing global demands and has incorporated various ICT based tools such as smart classroom, use of E-resources, online lectures, Google classroom, in their everyday teaching and learning process. The whole university has free Wi-Fi access to students and faculty members. The university has adopted a Mentor-Mentee system in all programmes where the role of a mentor is to identify the strengths, weaknesses of the students and help in the improvement of academic performance and future guidance. The university has been acknowledged for its excellence and creativity by various funding agencies of national/ international repute such as DST, ICMR, and UGC etc.

For each programme, the assessment process is well defined. The assessment process includes internal assessment which includes two sessional test and continuous assessment, and external assessment. The university also adopts various reforms such as re-evaluation, supplementary and special exam to make the assessment process more efficient and effective. The effectiveness of above reforms is evident by decrease in complaints/grievances about evaluation since last five years. As a result of the above initiatives, the pass percentage of students is 94.55% and the demand ratio for the last five years has risen to an impressive level.

Research, Innovations and Extension

The founder of Jamia Hamdard Late Hakeem Abdul Hameed was a philosopher, philanthropist and distinguished Unani physician with keen interest in evidence based medical practice. He always wanted to integrate convention knowledge with research. The vision and mission of the university during its existence of more than four decades encompasses providing quality higher education and undertake cutting-edge research at par with international standards in the fields of natural sciences, technology, health, humanities and other interdisciplinary fields. It promotes study of modern and traditional medicine systems encompassing a holistic and integrative approach to healthcare. Jamia Hamdard always strives to be in sync with national educational priorities, gender balancing, and equal opportunity for all students. There is a vibrant research milieu on campus. Research is managed by the Research and Development Cell established as per UGC guidelines.

Currently, Jamia Hamdard is recipient of infrastructure grants such as the PURSE, STUTI and several FIST programs of DST, several cycles of SAP program in almost all the Departments of SCLS, SPER, SEST and SIST. Recently AYUSH Ministry under the Centre for Excellence Scheme of the Ministry has established a CoE for Unani Medicine. The #1 rank in Pharmacy by NIRF for the 4th time in a row showcases the depth and potential of research of Jamia Hamdard. The JH faculty members working in various schools are also getting research funds from different government and non-government funding agencies, to the tune of 130 crores INR, with a share from all extra-mural funding agencies of the country. Jamia Hamdard has been an excellent

destination for young researchers as more than 800 JRF/SRF/RA/post-docs have availed funding from national agencies during the assessment period.

To maintain the excellence of quality research Jamia Hamdard has active MoUs for sharing and learning the research and innovations from institutions at national as well as global level. The university has a research promotion system and encourages the students and faculties through awards and incentives. JH has an Incubation Centre to inspire entrepreneurship and employment. An Intellectual Property Rights Cell and provision of Patent Fund help in filing patents; resulting in 85 patents has been filed/published. The University also focuses on the social outreach for community development through Unnat Bharat Abhiyan, skill based courses, health and hygiene awareness programmes, legal and cyber awareness programmes and national skills training centre.

Infrastructure and Learning Resources

Jamia Hamdard campus is green, plastic free and a no smoking campus located adjacent to Jahapanah City Forest. The 91.6 acres campus houses 9 academic buildings, a central library, convention centre, residential blocks for staff, 4 hostels for girl students and 2 hostels for boys, 2 guest houses, 2 hospitals (HAHC and Majeedia Hospital), botanical garden, pharmacy shops, banks, ATMs, convenient stores, post office, canteens and sports complex with many indoor and outdoor facilities. Campus provides a vibrant academic, sports and cultural environment for the holistic growth of students. The buildings are disabled friendly and the campus is secured 24x7 under the supervision of chief proctor, security in-charge and security guards.

University imparts education through classrooms equipped with modern facilities. There are 93 classrooms/tutorial rooms/seminar halls with ICT facility and well connected to network through Wi-Fi. There are around 100 states of the art laboratories for hands-on training of undergraduates, post-graduate, and Ph.D. students. There are also departmental instrumentation facilities, central instrumentation facilities, central animal house facility, bioinformatics facility and other sophisticated instrumentation facility like TEM, NMR, and LC-MS.

Jamia Hamdard focusses on the overall development of students. There are several sports and cultural activities being organized throughout the year. Indoor and outdoor sports facilities are available for both students and staff. Jamia Hamdard cricket ground also host tournaments organized by corporates and NGO from Delhi NCR. Extra-curricular talents of the students are nurtured through different clubs like Mental Health Club, Film and Drama Club, Literary Club, Sports Club, Yoga Club, Music Club, Eco Club and Mountaineering and Trekking Club.

Jamia Hamdard has a central library and seven associated school libraries. The library has a collection of over 2 lacs books including 116 rare in-house digitized books. Library also subscribes to different scholarly journals and online databases. Library is fully automated using LibSys Software and follows RFID based circulation system. Jamia Hamdard campus is Wi-Fi enabled with Internet speed of 1 GBPS provided by NKN, Govt. of India and a backup line of 100 Mbps from Spectranet, connected through fiber optical cable. There are around 6000 Wi Fi users and 2500 networking points spreading all around the campus. Staff members and research scholars are also provided with institutional email address.

Student Support and Progression

Student support and progression has been one of the most carefully drafted program of Jamia Hamdard. Facilities from academic support to social welfare schemes along with scholarships, sports, active alumni engagement, art and cultural activities have all been included in this domain. The percentage of students benefited by scholarships and fellowships provided by the institution, Government and non-government agencies (NGOs) during the last five years (except the reserved category scholarships) is very high. The institution has been providing career counselling and guidance to the students for competitive examinations NET. An average percentage of the number of students benefited by these schemes stands at 87 percent in the last five years. Capacity development and skill enhancement activities like soft skills, language and communication skills, life skills (Yoga, physical fitness, health and hygiene) and activities related to awareness of trends in technology are organised regularly by the institution. The Grievances Redressal Committee of the institution regularly address the cases of students related to ragging, sexual harassment, etc. and timely resolve the issues by appropriate mechanism.

The student progression can be analyzed through the average percentage of students qualifying the state, national and international level examinations, which constitutes about 85 percent during last five years. Moreover, the average placements of outgoing students every year is about 23 percent; whereas, the average percentage of students progressed to higher education constituted around 25 percent of all the outgoing students each year. Students have also been participating in various sports, art and cultural activities at inter-university, state, national and international levels and have been receiving several awards and medals. Student Council and its activities provide a platform for the students for an overall development. Along with organization of various events, students' council contributes in growth and recognition of university at national and international levels and this council is known as the Student's Advisory Council. The Alumni Association of Jamia Hamdard (TAAJH) has been contributing academically and financially to the institution. It is also actively engaged in organization of several programs of the alumni throughout the year.

Governance, Leadership and Management

Jamia Hamdard, a deemed to be university under Section 3 of the UGC Act 1956 conducts its activities as per its Memorandum Association (MoA) devised as per the UGC (Institutions Deemed to be Universities) Regulations 2019. Governance at various levels of organizational components is transparent and participatory. Schools, departments and centres of studies and research have been provided autonomy to conduct their business. Although Jamia Hamdard has been granted a 'Minority Institution' status by the National Commission for Minority Educational Institutions (NCMEI), it is open to all irrespective of community, region or country.

All the statutory bodies of Jamia Hamdard – Board of Management (BoM), Planning & Monitoring Board (PMB), Academic Council (AC), Finance Committee (FC), Internal Quality Assurance Cell (IQAC), and Research & Development Cell (RDC) are constituted as per UGC/NAAC norms and guided by the esteemed members drawn from the institution or outside including industry. The Ph.D. degree is awarded as per the UGC (Minimum Standards and Procedure for Award of MPhil/PhD Degrees) Regulations, 2016. All degrees are awarded as per UGC/Regulatory/Statutory Councils' norms. The Choice Based Credit System (CBCS), Outcome Based Education (OBE) and SWYAM-MOOCs guidelines have been implemented. The University Management System (UMS) has been in place in most of the activities. Library has Libsys in place and RFID has been installed. For research management a 'Research Management System (RMS)' platform has been developed. Jamia Hamdard web site is updated regularly.

The IQAC Committee chaired by the Vice Chancellor has representation of various stakeholders.

IQAC facilitates quality related aspects of academic and research, recruitment and promotion of faculty

members. It conducts programmes on quality and faculty development. IQAC also undertakes tasks submission of data for All India Survey of Higher Education (AISHE), and rankings conducted by NIRF, QS and THE. IQAC has developed manual and proforma for Academic and Administrative Audit (AAA) and coordinated Academic Audit of Schools/Department. Accounts of the university are audited as per protocol recommended by the UGC and other funding agencies. References MoA - <http://jamiahamdard.edu/UserPanel/DisplayPage.aspx?page=ka>
Composition of statutory bodies - 6/6.2.2_Statutory_bodies.pdf
IQAC home page- <http://jamiahamdard.edu/UserPanel/DisplayPage.aspx?page=o&ItemID=cag>

Institutional Values and Best Practices

Jamia Hamdard has adopted several institutional values and practices. It provides a safe environment for all and is proactive in fostering gender sensitivity and equality.

The institution uses solar energy and low-energy-consuming street LED lamps, and capacitors at load centers to improve voltage and power. The institution follows the 3R's: Reduce, Reuse and Recycle. For the management of waste within the campus, a MoU with Indian Pollution Control Association for organic, plastic waste management and Sorditcon Pvt. Ltd for e-waste management. Segregation of Organic Waste for Recycling and Treatment project has been functional. Effluent Treatment plant and Sewage Treatment Plant recycles liquid waste back to irrigate lawns and herbal gardens. Biomedical and Hazardous Waste management is undertaken by the Animal House. Rooftop rainwater harvesting and Surface Runoff Water Harvesting at girls' hostel, library building, are functional. The energy audit, and green audit, are in place. Ramps, lifts are constructed complying with the PWD/ CPWD norms. For disabled persons, it has dedicated washroom and website supports screen reading software. There are several signage and display boards available.

Festivals that cater to people of varied castes, religions, and creed are carried out to bring about the desired change in our thinking, and in building a harmonious environment. Commemorative days that bring a spirit of nationalism and environment-related, health related days are celebrated with enthusiasm. Code of conduct rules and regulations are well instructed. Constitutional obligations about rights, and duties is spread through minds of high thinking via lectures, and several social outreach programs. Besides, about 10-12 programs/ courses related to constitution are inculcated in the curriculum at various UG, PG and PhD. courses.

The university adopts and implements two best practices namely: 1. Social and Community Outreach initiatives are undertaken, as institutional social responsibility, which cater to the needy. 2. Integrative and Holistic model of Healthcare which is achieved through the preservation of traditional knowledge (Unani medicine) and transforming it into evidence-based medicine through an interdisciplinary approach. Jamia Hamdard strives to promote the study of modern and traditional medicine systems and healthcare, the priority of the institution.

2. PROFILE

2.1 BASIC INFORMATION

Name and Address of the University	
Name	JAMIA HAMDARD (HAMDARD UNIVERSITY)
Address	Mehrauli Badarpur Road, Hamdard Nagar
City	New Delhi
State	Delhi
Pin	110062
Website	www.jamiahamdard.edu

Contacts for Communication					
Designation	Name	Telephone with STD Code	Mobile	Fax	Email
Vice Chancellor	M. Afshar Alam	011-26059688	9891971999	-	vc@jamiahamdard.ac.in
IQAC / CIQA coordinator	Sheikh Raisuddin	011-26059666	9810370351	-	sraisuddin@jamiahamdard.ac.in

Nature of University	
Nature of University	Deemed University

Type of University	
Type of University	Unitary

Establishment Details	
Establishment Date of the University	10-05-1989
Status Prior to Establishment, If applicable	Affiliated College
Establishment Date	01-07-1963

Recognition Details		
Date of Recognition as a University by UGC or Any Other National Agency :		
Under Section	Date	View Document
2f of UGC	10-05-1989	View Document
12B of UGC	03-04-2018	View Document

University with Potential for Excellence	
Is the University Recognised as a University with Potential for Excellence (UPE) by the UGC?	No

Location, Area and Activity of Campus							
Campus Type	Address	Location*	Campus Area in Acres	Built up Area in sq.mts.	Programmes Offered	Date of Establishment	Date of Recognition by UGC/MHRD
Main campus	Mehrauli Badarpur Road, Hamdard Nagar	Urban	91.6	174270.6	Diploma, UG, PG, PhD		
<i>Off Campus</i>	<i>Near Kochipalli Kannur City Kodaparamba, Kannur, Kerala 670003</i>	<i>Urban</i>	<i>1.06</i>	<i>2275</i>	<i>UG, PG</i>	<i>15-10-2013</i>	<i>18-10-2013</i>

2.2 ACADEMIC INFORMATION

Furnish the Details of Colleges of University

Type Of Colleges	Numbers
Constituent Colleges	0
Affiliated Colleges	0
Colleges Under 2(f)	0
Colleges Under 2(f) and 12B	0
NAAC Accredited Colleges	0
Colleges with Potential for Excellence(UGC)	0
Autonomous Colleges	0
Colleges with Postgraduate Departments	0
Colleges with Research Departments	0
University Recognized Research Institutes/Centers	0

Is the University Offering any Programmes Recognised by any Statutory Regulatory Authority (SRA)	: Yes																
<table border="1"> <thead> <tr> <th>SRA program</th> <th>Document</th> </tr> </thead> <tbody> <tr> <td>AICTE</td> <td>108332_8638_1_1654073262.PDF</td> </tr> <tr> <td>PCI</td> <td>108332_8638_6_1654073383.pdf</td> </tr> <tr> <td>INC</td> <td>108332_8638_7_1654073568.pdf</td> </tr> <tr> <td>BCI</td> <td>108332_8638_8_1654073602.pdf</td> </tr> <tr> <td>CCIM</td> <td>108332_8638_10_1654073637.pdf</td> </tr> <tr> <td>MCI</td> <td>108332_8638_2_1657112694.pdf</td> </tr> <tr> <td>OT PT</td> <td>108332_8638_22_1654074179.pdf</td> </tr> </tbody> </table>	SRA program	Document	AICTE	108332_8638_1_1654073262.PDF	PCI	108332_8638_6_1654073383.pdf	INC	108332_8638_7_1654073568.pdf	BCI	108332_8638_8_1654073602.pdf	CCIM	108332_8638_10_1654073637.pdf	MCI	108332_8638_2_1657112694.pdf	OT PT	108332_8638_22_1654074179.pdf	
SRA program	Document																
AICTE	108332_8638_1_1654073262.PDF																
PCI	108332_8638_6_1654073383.pdf																
INC	108332_8638_7_1654073568.pdf																
BCI	108332_8638_8_1654073602.pdf																
CCIM	108332_8638_10_1654073637.pdf																
MCI	108332_8638_2_1657112694.pdf																
OT PT	108332_8638_22_1654074179.pdf																

Details Of Teaching & Non-Teaching Staff Of University

Teaching Faculty												
	Professor				Associate Professor				Assistant Professor			
	Male	Female	Others	Total	Male	Female	Others	Total	Male	Female	Others	Total
Sanctioned	72				66				356			
Recruited	45	27	0	72	30	35	1	66	160	196	0	356
Yet to Recruit	0				0				0			
On Contract	0	0	0	0	0	0	0	0	0	0	0	0

Non-Teaching Staff				
	Male	Female	Others	Total
Sanctioned				849
Recruited	619	160	0	779
Yet to Recruit				70
On Contract	55	35	0	90

Technical Staff				
	Male	Female	Others	Total
Sanctioned				441
Recruited	179	237	0	416
Yet to Recruit				25
On Contract	0	0	0	0

Qualification Details of the Teaching Staff

Permanent Teachers										
Highest Qualification	Professor			Associate Professor			Assistant Professor			Total
	Male	Female	Others	Male	Female	Others	Male	Female	Others	
D.sc/D.Litt/LLD/DM/MCH	1	0	0	0	0	0	0	0	0	1
Ph.D.	30	14	0	13	7	0	87	56	0	207
M.Phil.	0	0	0	0	0	0	0	1	0	1
PG	14	13	0	17	28	1	62	129	0	264
UG	0	0	0	0	0	0	0	0	0	0

Temporary Teachers										
Highest Qualification	Professor			Associate Professor			Assistant Professor			Total
	Male	Female	Others	Male	Female	Others	Male	Female	Others	
D.sc/D.Litt/LLD/DM/MCH	0	0	0	0	0	0	0	0	0	0
Ph.D.	0	0	0	0	0	0	0	0	0	0
M.Phil.	0	0	0	0	0	0	0	0	0	0
PG	0	0	0	0	0	0	11	10	0	21
UG	0	0	0	0	0	0	0	0	0	0

Part Time Teachers										
Highest Qualification	Professor			Associate Professor			Assistant Professor			Total
	Male	Female	Others	Male	Female	Others	Male	Female	Others	
D.sc/D.Litt/LLD/DM/MCH	0	0	0	0	0	0	0	0	0	0
Ph.D.	0	0	0	0	0	0	0	0	0	0
M.Phil.	0	0	0	0	0	0	0	0	0	0
PG	0	0	0	0	0	0	0	0	0	0
UG	0	0	0	0	0	0	0	0	0	0

Distinguished Academicians Appointed As

	Male	Female	Others	Total
Emeritus Professor	1	0	0	1
Adjunct Professor	30	5	0	35
Visiting Professor	0	0	0	0

Chairs Instituted by the University

Sl.No	Name of the Department	Name of the Chair	Name of the Sponsor Organisation/Agency
1	SUMER	Hakeem Abdul Hameed	Hamdard National Foundation

Provide the Following Details of Students Enrolled in the University During the Current Academic Year

Programme		From the State Where University is Located	From Other States of India	NRI Students	Foreign Students	Total
UG	Male	2261	2048	29	116	4454
	Female	1793	1178	29	95	3095
	Others	0	0	0	0	0
PG	Male	211	453	5	22	691
	Female	427	456	4	9	896
	Others	0	0	0	0	0
PG Diploma recognised by statutory authority including university	Male	15	46	0	0	61
	Female	14	57	0	2	73
	Others	0	0	0	0	0
Doctoral (Ph.D)	Male	55	153	0	9	217
	Female	139	167	0	7	313
	Others	0	0	0	0	0
Diploma	Male	69	153	0	1	223
	Female	113	71	0	3	187
	Others	0	0	0	0	0
Certificate / Awareness	Male	4	6	0	0	10
	Female	1	3	0	0	4
	Others	0	0	0	0	0
Pre Doctoral (M.Phil)	Male	2	6	0	8	16
	Female	6	3	1	9	19
	Others	0	0	0	0	0

Does the University offer any Integrated Programmes?	Yes
Total Number of Integrated Programme	0

Integrated Programme	From the State where university is located	From other States of India	NRI students	Foreign Students	Total
Male	41	48	0	2	91
Female	14	12	0	1	27
Others	0	0	0	0	0

Details of UGC Human Resource Development Centre, If applicable

Year of Establishment	Nil
Number of UGC Orientation Programmes	0
Number of UGC Refresher Course	0
Number of University's own Programmes	0
Total Number of Programmes Conducted (last five years)	0

Accreditation Details

Cycle Info	Accreditation	Grade	CGPA	Upload Peer Team Report
Cycle 1	Accreditation	A	85.6	NAAC Cycle 1 PTR report.pdf
Cycle 2	Accreditation	A	3.08	NAAC Cycle 2 PTR report.pdf
Cycle 3	Accreditation	A	3.15	NAAC_cycle 3 PTR report_final.pdf

2.3 EVALUATIVE REPORT OF THE DEPARTMENTS

Department Name	Upload Report
Anaesthesia	View Document
Anatomy	View Document
Biochemistry	View Document
Biochemistry Himsr	View Document
Biotechnology	View Document
Botany	View Document
Centre For Distance And Online Education	View Document
Centre For Federal Studies	View Document
Centre For Translational And Clinical Research	View Document
Chemistry	View Document
Community Medicine	View Document
Computer Sciences And Engineering	View Document
Ent	View Document
Food Technology	View Document
Hamdard Institute Of Legal Studies And Research	View Document
Hamdard Institute Of Medical Sciences And Research	View Document
Healthcare And Pharmaceutical Management	View Document
Hotel Management And Catering Technology	View Document
Ilmul Advia	View Document
Islamic Studies	View Document
Jamia Hamdard Institute Of Molecular Medicine	View Document
Jamia Hamdard Kannur Campus	View Document
Management	View Document
Media Education And Mass Communication	View Document
Medical Elementology And Toxicology	View Document
Medicine	View Document
Microbiology	View Document

Moalajat	View Document
Obst And Gynae	View Document
Ophthalmology	View Document
Orthopedics	View Document
Paediatrics	View Document
Paramedical Sciences	View Document
Pathology	View Document
Pharmaceutical Chemistry	View Document
Pharmaceutics	View Document
Pharmacognosy	View Document
Pharmacology	View Document
Pharmacology Himsr	View Document
Physiology	View Document
Radiodiagnostics	View Document
Rehabilitation Sciences	View Document
Rufaida College Of Nursing	View Document
Sist	View Document
Sper	View Document
Sumer	View Document
Surgery	View Document
Tahaffuzi Wa Samaji Tibb	View Document

Institutional preparedness for NEP

1. Multidisciplinary/interdisciplinary:	Being a multidisciplinary university, Jamia Hamdard (JH) is always in the forefront of promoting inter/trans/multi-disciplinary studies in all major and applied domains of knowledge systems. It is fundamentally committed towards promoting studies to sub serve national needs, and community interests, and to address the national and international challenges of human development and progress. Curricula include choice and credit-based courses, projects in the areas of community based services,
---	--

environmental education, and value-based courses towards the attainment of holistic and multidisciplinary education. Institutionally, Jamia Hamdard is committed to promote integrated / fusion studies through critical interface of science and social sciences. Also, Jamia Hamdard is probably one of the few universities which took lead in implementing NEP 2020 in its letter and spirit. In order to give effect to NEP 2020, the university vide its office order No: AS/NEP/JH-5/2022, dated 5th January 2022, constituted a seven-member committee to look into, and recommend a necessary road map for the implementation of NEP2020 in Jamia Hamdard. The committee after rounds of meetings and interactions with stakeholders recommended that : (I) NEP 2020 to be implemented from the academic session 2022-23; (II) non-council governed UG programs of studies be uniformly restructured to four years; (III) necessary course restructuring and curriculum revision including multidisciplinary choices, external credit earning, teachings of Indian culture, language, philosophy and constitution, skill generation, internship, exit and re-entry options, essential teachings of ecology, environment and disaster management, credits to range between 180-200, project/dissertation writing, re-designating certificate, diploma and degrees, etc., be in accordance with NEP 2020; (IV) establishment of academic credit bank; (V) gradually moving towards five years integrated/blended degree programs of studies, and (VI) phased introduction of one year PG program. 159 Standing Committee of the Academic Council held on 6th April 2022 has approved ‘in –principle the recommendations of the committee. In line with the above, course restructuring and curriculum revision (undergraduate) have been undertaken by the School of Chemical and Life Sciences in the subjects of Chemistry, Textile Chemistry, Botany, Biochemistry, Biotechnology, Toxicology & Clinical Research. Other non–Council governed UG courses are also being restructured. Needless to mention that curriculum revision takes due care to underline the importance of outcome-based education. A new four-year UG program, designed in accordance with NEP2020, in Politics and Governance was introduced in the Centre for Federal Studies, Public Policies and Governance. To add more to multidisciplinary, Jamia Hamdard has created many Centers of studies like

	Hamdard Institute of International Studies, Centre for Virology, Centre for Studies on Sufism in the Department of Islamic Studies, SHSS.
2. Academic bank of credits (ABC):	<p>1. Adoption of UGC (Establishment and Operationalization of Academic Bank of Credits (ABC) Scheme in Higher Education) Regulations, 2021 after notification. 2. Implementing the UGC Regulations on Academic Bank of Credits in a phased manner. 3. Considering universities/HEIs with equal or higher NAAC/NAC grades as equivalent for credit transfer. 4. Counting the credits acquired by the students from foreign Universities. 5. Awarding 1-2credits for Seva/Service/Community Service. 6. Credits in the courses of related streams, entrepreneurial competencies, communication, soft skills, etc. 7. More freedom to the student to earn the credits from institutes of higher learning located in India and abroad. 8. Restructuring academic programs of uniform and compatible credit pattern. 9. Constituting a committee to recommend the multidisciplinary courses and their credits. 10. On 12 May 2022, the university registered itself on the government platform Digi Locker NAD. The listed NAD ID is NAD012827. For credit posting on NAD, necessary guidelines are being devised.</p>
3. Skill development:	<p>Its stated vision (draft) reads “be a global leader, exemplar for integrating skills and value-added talents into teaching, research, operations, and public service. The university recognizes the need for a broad knowledge foundation in the development of long term vocational systems and pledges to consult with local and external business practitioners and skill/vocational experts on best practices and applications for community well-being.” This was discussed in detail by the 160 SC of AC held on 26th July 2022. University is in the process of establishing a new School of Vocational Education, Entrepreneurship and Training (SVEET) to initiate necessary skill generating-credit based programs for the UG and PG students. So far 30 programmes have been identified. The school is expected to engage industry veterans and others towards providing vocational skills. 1. Mapping of skills for better employability. 2. Introducing more programs in vocational education. 3. Introducing short-term skill-based programs. 4. Establishment of various clubs for co-curricular development and up-skilling of the</p>

	<p>students. 5. Revision of syllabi to integrate multidisciplinary skill component. 6. Identifying set of professional/life skills to be imparted across the disciplines. 7. Improving students' employability in local area. 8. Employability in cutting-edge areas. 9. Offering a course on value-based education. 10. Integrating skills and values in curriculum. 11. Curriculum rooted in ethics, Constitutional values and respect for Indian culture, art and heritage.</p>
<p>4. Appropriate integration of Indian Knowledge system (teaching in Indian Language, culture, using online course):</p>	<p>Jamia Hamdard is committed to incorporate following key points through the implementation of NEP 2020</p> <ol style="list-style-type: none"> 1. Including traditional Indian knowledge including tribal knowledge in the curriculum. 2. Promoting the culture of cross-disciplinary and interdisciplinary research. 3. Introduction of courses familiarizing the students about Indian culture and art. 4. Starting special scholarships for studies in Indian languages, arts, and culture. 5. Introducing the Departments of Music, Fine Arts, Translation and Interpretation, Comparative Literature, Philosophy and Performing Arts. 6. Establishment of various clubs for sports, dance, music, photography, fine arts, etc. 7. Introducing departments and programs in Indian languages. 8. Coordinating with classical language Institutions. 9. Coordination with National Mission for Mentoring for necessary support in teaching in Indian languages. 10. Pedagogy to make education more experiential and holistic. 11. Integrating sports in education to foster holistic development. 12. Character building and well-rounded individuals. 13. Multidisciplinary and holistic education across the domains. 14. Transforming the teachers with holistic professional development. 15. Restructuring the academic programs to impart multidisciplinary and holistic education.
<p>5. Focus on Outcome based education (OBE):</p>	<p>Learning outcome-based curriculum framework (LOCF) enabling the students to make a well-judged choice regarding the courses they wish to study, is a necessary component of NEP-2020 and the university has already endorsed it.</p>
<p>6. Distance education/online education:</p>	<p>Jamia Hamdard has a dedicated Centre for Online and Distance Learning offering UG & PG diploma programs. Under statutory approval of UGC, the Centre in 2021, has introduced online courses in select areas like BBA, BCA, B.Com. (H), M.A.</p>

(H.R) and M.A. (Islamic Studies). University will gradually move towards more and more online courses. 1. Optimum use of technology-based education platforms, such as DIKSHA/SWAYAM; 2. Creating initial versions of instructional materials and courses including online courses in cutting-edge domains and assessing their impact on specific areas such as professional education. 3. University may offer Ph.D. and PG programs in core areas such as Machine Learning as well as multidisciplinary fields and professional areas like health care, agriculture, and law through SWAYAM platform. 4. Blending of traditional teaching with the online in undergraduate and vocational programs. 5. Rigorous teacher training in learner-centric pedagogy and on how to become high quality online content creators using online teaching platforms and tools. 6. Online education to be blended with experiential and activity-based learning for desired outcomes. 7. Identifying different effective models of blended learning for different subjects while considering the essential importance of Face-to-Face learning. 8. Tools, such as, two-way video and two way-audio interfaces for holding online classes may be used as a popular mode of interaction particularly in pandemic like situations. 9. Digital content in multiple Indian languages to address the issue of linguistic diversity.

Extended Profile

1 Program

1.1

Number of programs offered year-wise for last five years

2021-22	2020-21	2019-20	2018-19	2017-18
81	108	94	94	77
File Description		Document		
Institutional data in prescribed format		View Document		

1.2

Number of departments offering academic programmes

Response: 48

2 Students

2.1

Number of students year-wise during last five years

2021-22	2020-21	2019-20	2018-19	2017-18
9254	8345	7092	6670	5912
File Description		Document		
Institutional data in prescribed format		View Document		

2.2

Number of outgoing / final year students year-wise during last five years

2021-22	2020-21	2019-20	2018-19	2017-18
3256	2345	2115	1796	1588
File Description		Document		
Institutional data in prescribed format		View Document		

2.3**Number of students appeared in the University examination year-wise during the last five years**

2021-22	2020-21	2019-20	2018-19	2017-18
8354	8127	6904	6431	5478
File Description		Document		
Institutional data in prescribed format		View Document		

2.4**Number of revaluation applications year-wise during the last 5 years**

2021-22	2020-21	2019-20	2018-19	2017-18
40	12	31	103	56

3 Teachers**3.1****Number of courses in all programs year-wise during last five years**

2021-22	2020-21	2019-20	2018-19	2017-18
3106	2999	2884	2758	2347
File Description		Document		
Institutional data in prescribed format		View Document		

3.2**Number of full time teachers year-wise during the last five years**

2021-22	2020-21	2019-20	2018-19	2017-18
494	458	461	426	372
File Description		Document		
Institutional data in prescribed format		View Document		

3.3

Number of sanctioned posts year-wise during last five years

2021-22	2020-21	2019-20	2018-19	2017-18
632	598	579	559	545
File Description		Document		
Institutional data in prescribed format		View Document		

4 Institution**4.1****Number of eligible applications received for admissions to all the programs year-wise during last five years**

2021-22	2020-21	2019-20	2018-19	2017-18
1535703	1282833	931236	518729	19838
File Description		Document		
Institutional data in prescribed format		View Document		

4.2**Number of seats earmarked for reserved category as per GOI/State Govt rule year-wise during last five years**

2021-22	2020-21	2019-20	2018-19	2017-18
1699	1659	1626	1547	1068
File Description		Document		
Institutional data in prescribed format		View Document		

4.3**Total number of classrooms and seminar halls****Response: 121****4.4****Total number of computers in the campus for academic purpose****Response: 1254**

4.5**Total Expenditure excluding salary year-wise during last five years (INR in Lakhs)**

2021-22	2020-21	2019-20	2018-19	2017-18
2266.00	5959.00	6535.00	7631.00	6908.00

4. Quality Indicator Framework(QIF)

Criterion 1 - Curricular Aspects

1.1 Curriculum Design and Development

1.1.1 Curricula developed and implemented have relevance to the local, national, regional and global developmental needs which is reflected in Programme outcomes (POs), Programme Specific Outcomes(PSOs) and Course Outcomes(COs) of the Programmes offered by the Institution.

Response:

Jamia Hamdard has designed the holistic curriculum that focuses on upholding the rich traditional values and at the same time incorporating the recent advances & technology. On one hand School of Unani Medicine and Educational Research offers programmes in Unani medicine, recognised as a centre of excellence by CCRUM and on the other hand B. Tech A.I., M.Sc. in virology programs are implemented due to emerging needs of recent COVID pandemic and has industry and society driven approach guided by PO's in alignment with its Vision and Mission and meeting requirements of its stakeholders.

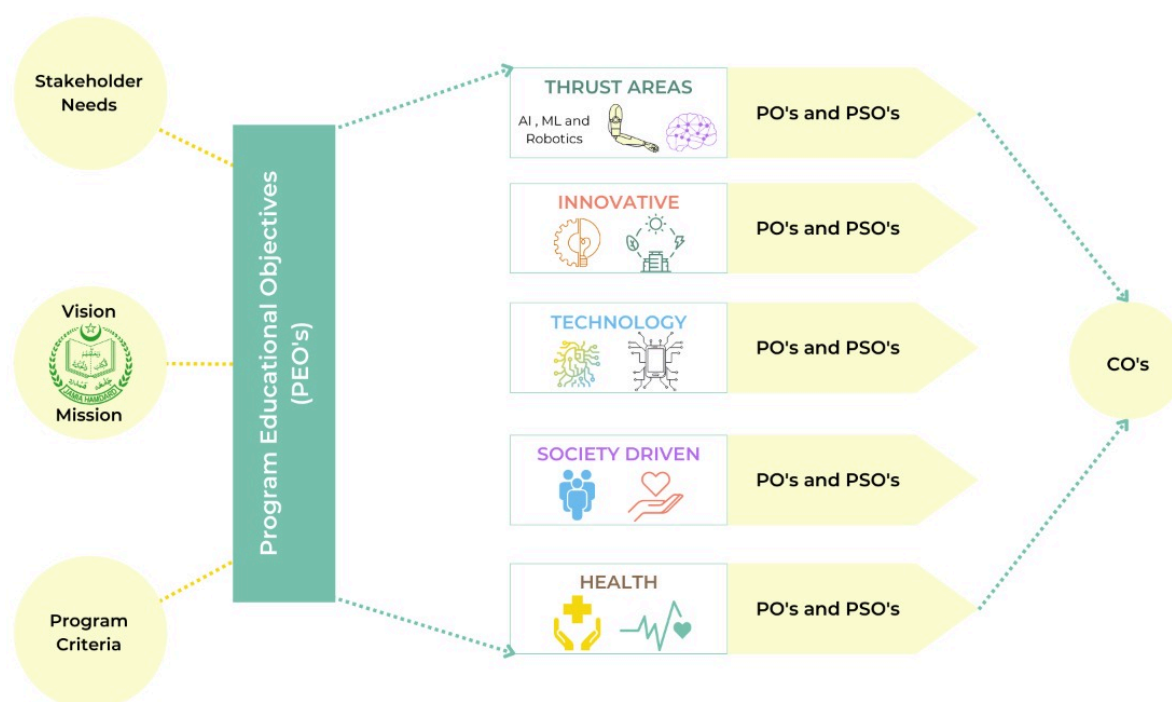

Process of Innovative, Technology, Industry and Society driven approach of Jamia Hamdard

Jamia Hamdard is fully prepared to implement The National Education Policy-2020 notified by the Government of India in phased manner with comprehensive strategic plan. Apart from core concepts, curriculum is focused on thrust areas like AI, ML and Robotics, health care, professional ethics, human values, industry compliant, environment and sustainability and oriented towards society and community.

Structured POs, COs and CLOs are formulated and practiced for the programs as a quality indicator for Outcome Based Education to meet the global needs and fulfil the graduate qualities by preparing them with long lasting aptitudes to confront real-time challenges, administration qualities, and make them part of corporate and social obligations. Attainment of COs is done to improvise the curricula and teaching

learning standards.

For catering to the local, national, regional and global developmental needs and commitment to quality higher education, all the departments have Board of studies which have experts to help in achieving the academic excellence. Regular Academic Council and Board of Studies meetings critically analyse the relevance of the programmes for meeting the changes in the community, hospitals and industry with inputs received from stakeholders in industry, nationally reputed institutions, research organizations as well as alumni, faculty and students and their guardians. For implementation of the outcome-based education within the framework of Choice Based Credit System pattern, Centre for Teaching Support and Innovations has been constituted through regular mentorship in Jamia Hamdard, which has been continuously working to achieve the goals set forth.

In keeping with the Learning Outcome-based Curricular Framework, all programs being offered by the university have learning targets and results that are connected to instructional methods and assessment/evaluation design. Learning, which is student-centric (courses, assignments, extended work, internship, field trip etc.), is typified through organized educational programs which experience intermittent surveys and undergo periodic reviews to form the educational module. Online courses such as MOOC and Spoken Tutorial offer enhanced learning encounters to the learners. Community and societal oriented curriculum engages students in social surveys to learn livelihood issues and recommend solutions.

Medical, Nursing, Paramedical, Rehabilitation, Pharmacy and Unani students are posted in multiple hospitals and communities for sufficient clinical exposure and to enhance their patient care skills. Technology and industry driven curriculum of Jamia Hamdard attempts to inculcate problem solving, analytical and critical thinking skills in the students in the thrust areas, helping them to address the societal problems at local, regional and global level and develop innovative products and technologies. Students are exposed to industry and clinical areas for skill development.

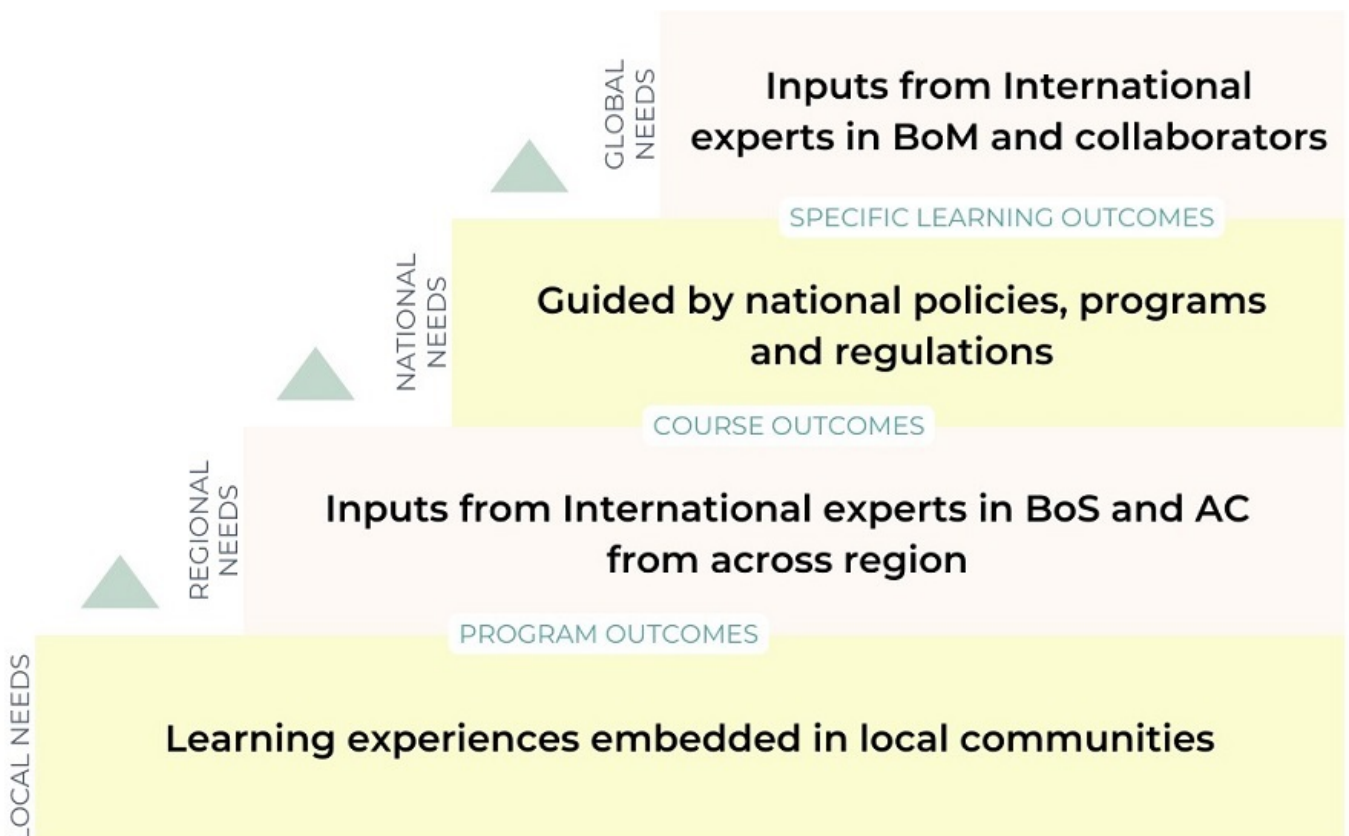

File Description	Document
Upload Additional information	View Document
Link for Additional information	View Document

1.1.2 Percentage of Programmes where syllabus revision was carried out during the last five years.

Response: 100

1.1.2.1 How many Programmes were revised out of total number of Programmes offered during the last five years

Response: 81

1.1.2.2 Number of all Programmes offered by the institution during the last five years.

Response: 81

File Description	Document
Minutes of relevant Academic Council/BOS meeting	View Document
Institutional data in prescribed format	View Document
Details of Programme syllabus revision in last 5 years	View Document
Any additional information	View Document
Link for additional information	View Document

1.1.3 Average percentage of courses having focus on employability/ entrepreneurship/ skill development offered by the institution during the last five years

Response: 77.05

1.1.3.1 Number of courses having focus on employability/ entrepreneurship/ skill development year-wise during the last five years

2021-22	2020-21	2019-20	2018-19	2017-18
2407	2322	2232	2134	1773

File Description	Document
Programme/ Curriculum/ Syllabus of the courses	View Document
MoU's with relevant organizations for these courses, if any	View Document
Minutes of the Boards of Studies/ Academic Council meetings with approvals for these courses	View Document
Institutional data in prescribed format	View Document
Any additional information	View Document

1.2 Academic Flexibility

<p>1.2.1 Percentage of new courses introduced of the total number of courses across all programs offered during the last five years.</p> <p>Response: 36.99</p>	
<p>1.2.1.1 How many new courses were introduced within the last five years.</p> <p>Response: 1149</p>	
<p>1.2.1.2 Number of courses offered by the institution across all programmes during the last five years.</p> <p>Response: 3106</p>	
File Description	Document
Minutes of relevant Academic Council/BOS meeting	View Document
Institutional data in prescribed format	View Document
Any additional information	View Document
<p>1.2.2 Percentage of Programmes in which Choice Based Credit System (CBCS) / elective course system has been implemented (Data for the latest completed academic year).</p> <p>Response: 100</p>	
<p>1.2.2.1 Number of Programmes in which CBCS / Elective course system implemented.</p> <p>Response: 81</p>	

File Description	Document
Minutes of relevant Academic Council/BOS meetings	View Document
Institutional data in prescribed format	View Document
Any additional information	View Document

1.3 Curriculum Enrichment

1.3.1 Institution integrates crosscutting issues relevant to Professional Ethics ,Gender, Human Values ,Environment and Sustainability into the Curriculum

Response:

Courses offered by Jamia Hamdard emphasize inclusiveness and holistic development of students paying special attention to professional ethics, gender, human values, environment and sustainability in accordance with the rules of regulatory bodies. Integration of such courses gives a conducive environment for all-around development of the students and inculcates values of justice and sense of responsibility towards society in them.

Professional Ethics and Human Values

Courses pertaining to professional ethics and human values are offered across various disciplines both for UG and PG students namely Humanities, Universal Human Values, Constitution of India and several other courses on professional ethics propelling decision-making and advancing best business practices.

Medical ethics, community health and nursing courses involve students in several community service activities like training programs for young boys and girls in collaboration with Delhi police, NGOs, visiting old age homes, juvenile shelter homes and spastic and mentally retarded children centers, organizing blood donation camps, free health check-up and referral camps, community mass health education and awareness programmes and carrying out cleanliness and vaccination drives, besides helping patients admitted in Majeedia quarantine center and COVID Care Center during the COVID-19 pandemic when society actually needed it the most.

Courses like Environmental Studies, Disaster Management, IPR, Cyber laws and Ethics, Humanities-II, Social Media and Social Media Ethics, offer value education to UG and PG students and groom them for value oriented-life.

Human Rights and Duties in India and Gender Youth and Society course curricular activities infuse a sense of “Unity in Diversity” among the students.

Community Medicine course encourage student participation in Unnat Bharat Abhiyan from the year 2019, by adopting 5 villages and successful implementation of the COVID project in 2020 and continues to do so.

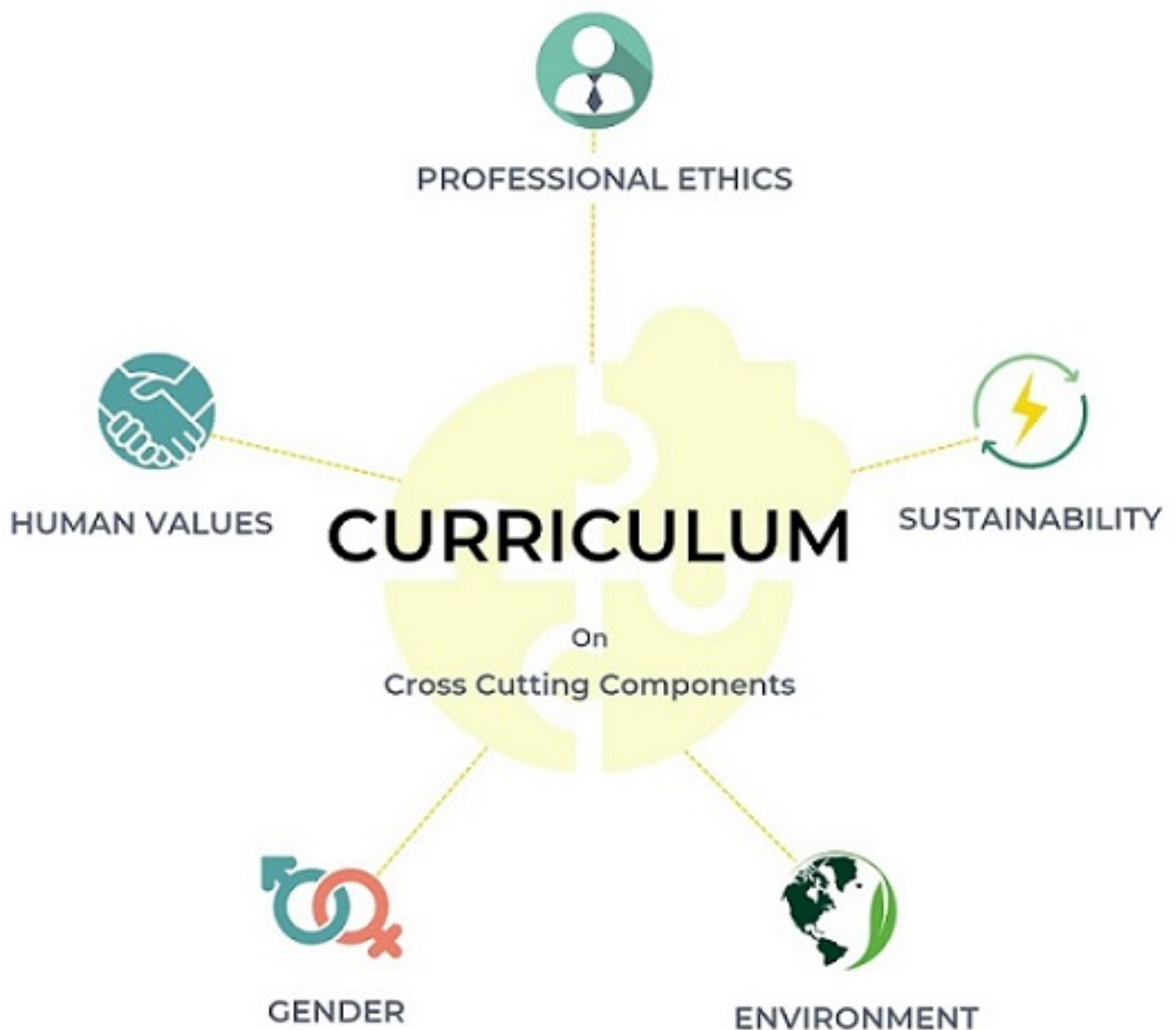

Gender

With 50% of the students studying in Jamia Hamdard being girls, gender-related matters are conceptually interlaced into educational modules investigating the rise of gender issues, sensitization, entrepreneurial openings, group activities, women in literature and other issues related to the wellbeing of girl students.

Every year, interactive sessions, Girl Up programs on women empowerment and honouring women entrepreneurs are organized on International Women's Day.

Internal Complaint Committee (ICC), Equal opportunity cell and Women's Grievances Redressal Cell, are in place to address grievances, issues of sexual harassment, if any, and in educating the students about gender equality, women empowerment and safe-guarding the women employees and female students of the institution.

Environment and Sustainability

Courses on Environment Science, Environment Studies and Disaster Management, Animal Welfare in Toxicology, Animal Biotechnology help in making the students environment conscious and aware about biodiversity, environment pollution, global warming, green computing, waste management, disaster management and related issues.

Courses on Biosafety and Bioethics, Biotechnology & Human Health, and Environmental & Ethical Aspects sensitize students to these issues. Students participate in awareness campaigns, debates, and exhibitions on environment and sustainability issues in particular and community at large. Jamia Hamdard Environment club and Environmental Quality Cell (EQC) are committed to minimize the negative environmental impact not only in Jamia Hamdard campus, but also its surroundings to help develop a cleaner and greener environment and more sustainable world.

File Description	Document
Upload the list and description of the courses which address the Gender, Environment and Sustainability, Human Values and Professional Ethics into the Curriculum	View Document
Any additional information	View Document

1.3.2 Number of value-added courses for imparting transferable and life skills offered during last five years.

Response: 392

1.3.2.1 How many new value-added courses are added within the last five years.

Response: 392

File Description	Document
Institutional data in prescribed format	View Document
Brochure or any other document relating to value added courses	View Document
Any additional information	View Document

1.3.3 Average Percentage of students enrolled in the courses under 1.3.2 above.

Response: 36.02

1.3.3.1 Number of students enrolled in value-added courses imparting transferable and life skills

offered year-wise during the last five years.

2021-22	2020-21	2019-20	2018-19	2017-18
2995	3445	2707	2410	1902

1.3.4 Percentage of students undertaking field projects / research projects / internships (Data for the latest completed academic year).

Response: 75.5

1.3.4.1 Number of students undertaking field projects or research projects or internships.

Response: 6987

File Description	Document
List of Programmes and number of students undertaking field projects research projects / internships (Data Template)	View Document
Any additional information	View Document
Link for additional information	View Document

1.4 Feedback System

1.4.1 Structured feedback for design and review of syllabus – semester-wise / year-wise is received from 1) Students, 2) Teachers, 3) Employers, 4) Alumni

Response: A. All 4 of the above

File Description	Document
URL for stakeholder feedback report	View Document
Institutional data in prescribed format	View Document
Action taken report of the University on feedback report as stated in the minutes of the Governing Council, Syndicate, Board of Management (Upload)	View Document

1.4.2 Feedback processes of the institution may be classified as follows:

Response: A. Feedback collected, analysed and action taken and feedback available on website

File Description	Document
URL for feedback report	View Document
Upload any additional information	View Document
Institutional data in prescribed format	View Document

Criterion 2 - Teaching-learning and Evaluation

2.1 Student Enrollment and Profile

2.1.1 Demand Ratio (Average of last five years)

Response: 260.34

2.1.1.1 Number of seats available year wise during the last five years

2021-22	2020-21	2019-20	2018-19	2017-18
3399	3318	3252	3095	2137

File Description

Document

Demand Ratio (Average of Last five years) based on Data Template upload the document

[View Document](#)

• Any additional information

[View Document](#)

2.1.2 Average percentage of seats filled against reserved categories (SC, ST, OBC, Divyangjan, etc.) as per applicable reservation policy during the last five years (Excluding Supernumerary Seats)

Response: 89.02

2.1.2.1 Number of actual students admitted from the reserved categories year wise during last five years

2021-22	2020-21	2019-20	2018-19	2017-18
1647	1500	1334	1254	1011

File Description

Document

Average percentage of seats filled against seats reserved (Data Template)

[View Document](#)

Any additional information

[View Document](#)

2.2 Catering to Student Diversity

2.2.1 The institution assesses the learning levels of the students and organises special Programmes for advanced learners and slow learners

Response:

Jamia Hamdard has focused on imparting equitable education to learners from different socio-economical-cultural background with varying learning abilities.

Students Assessment

The student assessment system comprises qualitative and quantitative methodologies including examination systems: Sessional and Semester/annual and other assessment techniques such as class room response, quiz, presentations, seminar, project works, field visit reports, paper and poster presentations, workshops, and extra-curricular activities.

Based on the mentioned assessment techniques the students are mapped into slow and advanced learners

Identification of the Type of Learners

Based on the assessment methodologies, students are identified as advanced learners or slow learners. Slow learners are furthermore mapped into domain-based slow learners and overall slow learners.

- Domain-based slow learners: Students mapped into this category are selective learners who are slow learners in one of the subjects/domains but grasp the fundamental and conceptual teachings of other subjects/domains.
- Overall slow learners: Students mapped into this category are slow in more than one subject/domain.

Programs for Slow Learners

Students identified to be subject-specific slow learners are provided with the following programs through which they can identify their area of expertise to enrich that domain and strengthen the subject-specific domains

- The university has adopted a Mentor-Mentee system where the role of mentors is to identify the strengths, weakness of the slow learners and helps in the improvement of academic performance.
- Remedial classes to help struggling learners improve their knowledge and clear their concepts.
- Special examinations are also periodically organized for these students to help them in moving ahead in their academic sessions.
- Group-based learning where the peer-teaching practice is encouraged.
- Apart from examinations, students are tasked with regular submission of assignments for individual subjects, and project work where they can incorporate the theoretical learning into a more practical outcome
- The university also ensures that the slow learners complete their course within the span period and extra attention is provided to make them employable.
- Student-centeredness is a priority for faculty members, and they make themselves available to students via email, phone, and other forms of interaction.

Programs and Acknowledgement for Advanced Learners

- Students are encouraged to participate in national and international level project based events and

competitions.

- Industry collaborated on advanced project-based learning
- Mentor/Counselling sessions are provided for students who excel in certain domains and need further guidance
- Students are encouraged to write research papers, meta-analyses, narrative reviews, technical article writing, paper presentation, poster presentation
- Advanced learners are appointed as secretaries in various extracurricular clubs such as music club, athletics club, mental health club, yoga club, and literary club to improve their confidence, for personality development, leadership training, and competency building.
- For advanced learners university encourages and motivates students to represent university in various conferences/ workshops/ inter-university competitions/ extra-curricular activities/ exhibition
- University provides scholarships to meritorious students
- University honours top merit students with the gold medal at the annual convocation event.
- On National Science Day every year, the university rewards students who publish papers in high-impact journals with certificates of appreciation and cash incentives.

File Description	Document
Upload Any additional information	View Document
Paste link for additional information	View Document

2.2.2 Student - Full time teacher ratio (Data for the latest completed academic year)

Response: 19:1

File Description	Document
Any additional information	View Document

2.3 Teaching- Learning Process

2.3.1 Student centric methods, such as experiential learning, participative learning and problem solving methodologies are used for enhancing learning experiences

Response:

Jamia Hamdard lays a major focus on using student-centred teaching approaches to improve learning and prepare students to solve societal and global concerns. The whole process of teaching-learning involves the need, interest, and capabilities of the student based on the feedback obtained along with teacher observation. Some of the methods used for enhancing learning in Jamia Hamdard:-

Problem Solving Method:

- Teaching students how to recognize problems, comprehend them, and apply the decision-making

process.

- Projects, and research at undergraduate and postgraduate levels to develop analytical thinking.
- Hands-on skill development workshops to develop their skills and practical knowledge in the relevant subjects, provide opportunities for students to work in their subject of interest, and enhance innovation and problem-solving ability.
- Brain-storming sessions for diagnosis and treatment planning of patients in the hospital.
- Aptitude enhancement courses (management and ethics based) to develop the thought process required for problem-solving.
- Expert lectures / guest lectures by industry experts.

2. Experiential Learning:

- Compulsory internships and clinical training for Nursing, Medical and Allied Health Courses to enrich the student's practical skills and knowledge.
- Projects and dissertation work to help utilize the theoretical knowledge.
- Student collect and analyze data, prepare research paper, develop hypotheses and experimental design, perform research, analyze and interpret results, and present them in conferences/seminars.
- Students of appropriate programmes are taken for field, hospital, and specialized lab visits to demonstrate.
- Herbal garden is used to familiarize students with the medicinal importance of herbs and the collection of flora.
- There are specialized research laboratories in the field of Toxicology, Biotechnology, Biochemistry, and Pharmacy funded by various national agencies such as DST and UGC FIST with the state of the art equipment to ensure that students can perform the experimental work using theory-based learning.
- The university has simulation-based software's, high-processing computer systems, and high-speed LAN connections to conduct virtual experiments and access information.
- Field-based interaction with the community's help students gain insight into their problems and devise solutions to their problem in various fields of science and technology, health, education.

3. Participative Learning:-

- Assignments, seminar presentations (Individual and Team based), case study presentations, and discussions by the students are conducted to enhance their confidence, communication and skills.
- Students undertake research work and publish them in reputed national and international journals.
- Online journals, invited lectures, educational videos, and symposia support the teaching-learning process by augmenting the student knowledge and awareness.
- Free Wi-Fi campus to support educational activities and facilitate access to online resources.
- The NSS Cell and the NCC sub-unit are open to students of all genders.
- Jamia Hamdard has constituted Innovation and Incubation Cell to encourage students to develop new and innovative models.
- Students are also encouraged to participate in various co-curricular activities to develop inclination towards creative art, culture and diverse and ethnic culture of India, leadership and collaboration abilities.

4. ICT based Teaching

- Both university and faculties have YouTube channels, e-pathshala and slide share content to live

stream, upload various informative webinars, and lectures.

- ICT-equipped smart classes for teaching and learning
- Efficient use of Google Meet, Google Classroom, and Google Group to provide reading materials and subject knowledge.

File Description	Document
Upload any additional information	View Document
Link for Additional Information	View Document

2.3.2 Teachers use ICT enabled tools including online resources for effective teaching and learning process.

Response:

Jamia Hamdard has been actively involved in adopting the use of ICT-enabled tools and resources in the teaching-learning process.

Following is the list of ICT tools used:-

1. Laptops/Smart Devices

The faculty members have laptops with all the necessary software required for teaching. Also, all the offices and departments have an adequate number of desktop computers. The central computer lab is equipped with high processing computer systems which are connected over a high-speed internet service and the latest software used for training and teaching purposes.

2. Classrooms with ICT tools

University has ICT-enabled classroom and smart classes which includes LCD/LED projectors, computers, and mikes. University also has smart classes and lectures/seminar halls equipped with the latest ICT technology.

3. Wi-Fi

Jamia Hamdard has Wi-Fi facilities for all students and teachers. The Wi-Fi services are secure with a unique username and password for each teacher and student. The Wi-Fi can be accessed from anywhere in the university.

4. E-Resources from Library

- The student has access to E-resources and journals available in the library.
- A variety of bibliographic databases, such as a database for printed books, theses, and CDROMs are available in English, Urdu, Hindi, Persian and Arabic languages. These various databases are available to be accessed throughout the campus and beyond in 24x7 format on the Intranet and

Internet topography.

- All library members are provided bar-coded library IDs with category-specific privileges for borrowing materials from any issue counter within the library system.
- The library also introduced biometric fingerprint access and a charging/discharging control system in the Central Library to facilitate real-time records of footfalls in the library.
- The RFID-based circulation system is facilitating library users to check themselves and save time.
- University has subscribed to online databases like DELNET, J-Gate, Business Source Ultimate, India Business Insight, SCC Online, LexisNexis, and Economic & Political Weekly (Magazine).
- The Central Library undertakes compulsory checking of all research papers and doctoral thesis through the 'Urkund' software for which online links have been provided by the INFLIBNET, Ahmedabad.

5. ICT Tools used for Teaching

- Many teachers also maintain their own YouTube channel through which they impart teaching and provide access to multiple learning resources.
- Faculties utilize YouTube, Google Meet, and Google Classroom platforms to communicate, provide material and syllabus, make announcements, conduct tests, and upload assignments.
- Faculty members are using IT-enabled learning tools such as PPT, Video clippings, and online sources for enhancing knowledge and practical learning

6. E-Resources available online

E-resources available on various educational websites such as SWAYAM, e-PG Pathshala, SWAYAMPURABHA, National Digital Library, Shodhganga, Vidwan, NPTEL, COURSERA, and the UGC online lecture series are accessible to Students.

File Description	Document
Upload any additional information	View Document
Provide link for webpage describing the " LMS/ Academic management system"	View Document

2.3.3 Ratio of students to mentor for academic and other related issues (Data for the latest completed academic year)

Response: 19:1

2.3.3.1 Number of mentors ?????????????? ????????

Response: 494

File Description	Document
Upload year wise, number of students enrolled and full time teachers on roll.	View Document
Circulars pertaining to assigning mentors to mentees	View Document

2.4 Teacher Profile and Quality

2.4.1 Average percentage of full time teachers against sanctioned posts during the last five years	
Response: 75.77	
File Description	Document
Year wise full time teachers and sanctioned posts for 5 years	View Document
List of the faculty members authenticated by the Head of HEI	View Document
Any additional information	View Document

2.4.2 Average percentage of full time teachers with Ph.D./D.M/M.Ch./D.N.B Superspeciality/D.Sc./D’Lit. year-wise during the last five years											
Response: 64.63											
2.4.2.1 Number of full time teachers with <i>Ph. D. / D.M. / M.Ch. / D.N.B Superspeciality / D.Sc. / D.Litt.</i> year wise during the last five years											
<table border="1"> <thead> <tr> <th>2021-22</th> <th>2020-21</th> <th>2019-20</th> <th>2018-19</th> <th>2017-18</th> </tr> </thead> <tbody> <tr> <td>330</td> <td>310</td> <td>312</td> <td>260</td> <td>223</td> </tr> </tbody> </table>	2021-22	2020-21	2019-20	2018-19	2017-18	330	310	312	260	223	
2021-22	2020-21	2019-20	2018-19	2017-18							
330	310	312	260	223							
File Description	Document										
List of number of full time teachers with Ph D/D M/M Ch/D N B Superspeciality/DSc/D Lit and number of full time teachers for 5 years	View Document										
Any additional information	View Document										

2.4.3 Average teaching experience of full time teachers in the same institution (Data for the latest completed academic year in number of years)
Response: 8.62

2.4.3.1 Total experience of full-time teachers

Response: 4258

File Description	Document
List of Teachers including their PAN, designation, dept and experience details	View Document
Any additional information	View Document

2.4.4 Average percentage of full time teachers who received awards, recognition, fellowships at State, National, International level from Government/Govt. recognised bodies during the last five years

Response: 103.8

2.4.4.1 Number of full time teachers receiving awards from state /national /international level from Government/Govt. recognized bodies year wise during the last five years

2021-22	2020-21	2019-20	2018-19	2017-18
104	98	96	89	72

File Description	Document
Institutional data in prescribed format	View Document
e-copies of award letters (scanned or soft copy)	View Document

2.5 Evaluation Process and Reforms**2.5.1 Average number of days from the date of last semester-end/ year- end examination till the declaration of results year-wise during the last five years**

Response: 36.61

2.5.1.1 Number of days from the date of last semester-end/ year- end examination till the declaration of results year wise during the last five years

2021-22	2020-21	2019-20	2018-19	2017-18
36.22	56.25	30.78	24.13	35.65

File Description	Document
List of Programmes and date of last semester and date of declaration of results	View Document
Any additional information	View Document

2.5.2 Average percentage of student complaints/grievances about evaluation against total number appeared in the examinations during the last five years

Response: 0.74

2.5.2.1 Number of complaints/grievances about evaluation year wise during the last five years

2021-22	2020-21	2019-20	2018-19	2017-18
40	12	31	103	56

File Description	Document
Number of complaints and total number of students appeared year wise	View Document
Any additional information	View Document

2.5.3 IT integration and reforms in the examination procedures and processes (continuous internal assessment and end-semester assessment) have brought in considerable improvement in examination management system of the institution

Response:

Examination Process

- A unique roll number is assigned to each student and each course has been allotted with a unique code.
- Online payment through a secured payment gateway facility for fee payment, transcripts, mark sheets, and examination fees.

Evaluation Process

- External and internal assessment weightage are 75:25 for undergraduate and post-graduation programs (subject to statutory council recommendations).
- University has established an Academic Resource Management System (ARMS) for the tabulation of the mark and timely declaration of results of the University Examination. A digital entry of marks helps to maintain uniformity and accuracy.
- The detail of students of each course along with their roll no. appearing in the exam is already

available in the ARMS system

- Tabulators are assigned from each department who enters internal assessment and external assessment marks against each student through their unique login id and password to maintain secrecy and transparency.
- This facilitates accurate calculation of SGPA and percentage of students.
- The marks entered are later approved by the Head of the Department, Examination Department which ensures zero chances of error.
- Mark sheets and degree certificates have 12 security features.

Result Declaration

- After entering marks in ARMS system results are generated. Results are also declared on Jamia Hamdard website
- Once the result is declared mark sheets/ provisional degree/certificates are issued to the students.
- Jamia Hamdard has an in-house printing facility to print mark sheet/ degree/certificates. The degree/ certificates/ mark sheets are printed with security features like the Jamia Hamdard logo watermark to ensure originality.
- All degrees and certificates uploaded on to National Digital Library for easy access to students.
- Jamia Hamdard has joined the National Academic Depository (NAD) DIGILOCKER system.

Additional Reforms

- **Confidentiality:** For each subject, at least three teachers are nominated in the panel for making question paper. Out of the three, only one teacher is selected for making a question paper by the competent authority. Teachers from other institutes are selected either for making question paper and evaluation. Viva-voce examination is conducted by the external experts to promote transparency in the evaluation procedure.
- **Re-Evaluation:-**If the students are not satisfied with their marks/grades, the university has a provision for re-evaluation of their answer sheets at the request of the student through the channel.
- **Supplementary Exams and Special Exam:** The supplementary exam is conducted to provide students an opportunity to retake the exam in case they have a backlog or they missed some exams. A special exam is conducted for those who have failed in all attempts provided according to the Byelaws.
- **Unfair Means:** University also has a policy for those students who were caught using unfair means in the exam. Once an unfair means is reported, the matter is brought for deliberation and action by the Proctorial Committee.
- **Flying Squad:** University also appoints flying squad for keeping vigil on the paper conducted every day
- **Academic Calendar:** At the beginning of each semester/ year, the academic calendar is prepared and strictly followed for the timely completion of the course and declaration of result

File Description	Document
Year wise number of applications, students and revaluation cases	View Document
Any additional information	View Document
Link for additional information	View Document

2.5.4 Status of automation of Examination division along with approved Examination Manual

Response: Only student registration and result processing

File Description	Document
Current manual of examination automation system and Annual reports of examination including the present status of automation	View Document
Current Manual of examination automation system	View Document
Any additional information	View Document

2.6 Student Performance and Learning Outcomes

2.6.1 The institution has stated learning outcomes (generic and programme specific)/graduate attributes which are integrated into the assessment process and widely publicized through the website and other documents

Response:

The curriculum is designed according to well-defined program specific learning outcomes

Mapping of Course Outcome

- Course outcomes are designed by the faculty reflecting the skills and abilities that the students must develop along with disciplinary & interdisciplinary knowledge.
- The learning outcome of every course is designed to inculcate professionalism, ethical conduct, and respect for cultural diversity.
- The course outcomes are defined and mapped with programme outcomes and programme specific outcomes for each course.
- The mapping is done through Program Articular Matrix (PAM) which shows the relation between course outcome and programme outcome.
- This process of mapping the entire curriculum has helped increase the knowledge depth of the student which is being imparted to them through the practical and theoretical teaching process.
- For each programme, the assessment process is well defined and includes:-1. Internal Assessment which comprises two sessional tests and continuous assessment, and 2. External Assessment.

Publication of Learning Outcomes

- Modification in course objectives and its curriculum is done through the Board of Studies and Academic Council.
- Revision in programme outcome, programme specific outcome, and course outcome is done after the approval of the school board, Board of Studies, and Academic Council
- Widely publicized as a Byelaws and syllabus on the university website.
- Printed copies are available in the respective departments for ready reference to the stakeholders of the school including students, faculties, etc.
- At the start of each semester, the faculty members discuss with the student about the course outcome and assessment process.

All these measures and practices have helped the student for developing a holistic understanding of the subject to aid them in serving society through their acquired knowledge.

2.6.2: Attainment of Programme outcomes, Programme specific outcomes and course outcomes are evaluated by the institution

The schools have initiated very effective methodologies which make sure that POs, PSOs, and COs based curriculum are attained by imparting information & knowledge to the students in an efficient manner. Moreover, classroom-based pedagogical learning or fieldwork-based surveys are employed where students interact with people from different strata of society.

Evaluation Process

- The medical and allied courses have their evaluation process according to the guidelines of their respective council to maintain a uniform standard.
- Internal assessment and external assessment in each semester of the academic session.
- Assessment is also done through class, group discussions, topic-based presentations, mock tests, quizzes, assignments, project works, case studies, *etc.* Weightage is also allocated to attendance and attentiveness in the class.
- The marks and points scored in both the form of assessments are taken into consideration while calculating the overall score of the students for any particular subject.
- Apart from this for more enhanced assessment of students and to introduce a sense of market/society based learning model instead of the older pedagogical methodologies based models students are encouraged to be involved in the project works, seminars on the latest topics, internships, research paper writing, etc.
- University also conducts various activities such as sports and cultural events, NCC, NSS activities, and awareness lectures to attain the course outcomes

File Description	Document
Upload any additional information	View Document
Paste link for Additional Information	View Document

2.6.2 Attainment of Programme outcomes, Programme specific outcomes and course outcomes are evaluated by the institution

Response:

The schools have initiated very effective methodologies which make sure that POs, PSOs, and COs based curriculum are attained by imparting information & knowledge to the students in an efficient manner. Moreover, classroom-based pedagogical learning or fieldwork-based surveys are employed where students interact with people from different strata of society.

Evaluation Process

- The medical and allied courses have their evaluation process according to the Guidelines of their respective Council to maintain a Uniform Standard.
- Internal assessment and External assessment in each semester of the academic session.
- Assessment is also done through class, group discussions, topic-based Presentations, mock tests, quizzes, assignments, project works, case studies, *etc.* Weightage is also allocated to attendance and attentiveness in the class.
- The marks and points scored in both the form of assessments are taken into consideration while calculating the overall score of the students for any particular subject.
- Apart from this for more enhanced assessment of students and to introduce a sense of market/society based learning model instead of the older pedagogical methodologies based models students are encouraged to be involved in the project works, seminars on the latest topics, internships, research paper writing, *etc.*
- University also conducts various activities such as sports and cultural events, NCC, NSS activities, and awareness lectures to attain the course outcomes

File Description	Document
Upload any additional information	View Document
Paste link for Additional Information	View Document

2.6.3 Pass Percentage of students(Data for the latest completed academic year)

Response: 94.56

2.6.3.1 Total number of final year students who passed the examination conducted by Institution.

Response: 748

2.6.3.2 **Total number of final year students who appeared for the examination conducted by the Institution.**

Response: 791

File Description	Document
Upload list of Programmes and number of students passed and appeared in the final year examination	View Document
Upload any additional information	View Document

2.7 Student Satisfaction Survey

2.7.1 Online student satisfaction survey regarding teaching learning process	
Response: 3.02	
File Description	Document
Upload database of all currently enrolled students	View Document

Criterion 3 - Research, Innovations and Extension

3.1 Promotion of Research and Facilities

3.1.1 The institution's Research facilities are frequently updated and there is a well defined policy for promotion of research which is uploaded on the institutional website and implemented

Response:

Jamia Hamdard (JH) has created an operational research ecosystem to support and promote interdisciplinary and multidisciplinary research work through various research facilities. The research ecosystem is managed through Director Research and Development Cell. To maintain research ethics in JH various research committee, look after ethical issues namely JH-Institutional Review Board, Institutional Animal Ethics Committee, Institutional Biosafety Committee and Institutional and Academic Integrity Panels etc. The laboratories have been upgraded which has further improved competencies among faculty and research students. The departments have upgraded equipment in the laboratories to facilitate research of high standards using grants like DST PURSE, DST FIST, UGC SAP, AYUSH CoE and other funded research projects.

A Centre for Innovation, Incubation and Entrepreneurship (CIIE) Jamia Hamdard, has been created to grow the inner skills of the youth and the academician around the universities and utilize them to the best of its capabilities to meet the vision of Atmanirbhar Bharat and Make in India Model, and the undergraduates are targeted at early stage to conduct research. With the adoption of collaborative and inclusive approaches, the quantum of research output of Jamia Hamdard in terms of both quality and quantity is remarkable which is evident through bibliometric indices.

The research ecosystem has promoted human resource development and capacity generation for basic and translational research. JH conducts a series of summer schools, orientation programs, workshops, seminars, invited talks, training programs of national and international levels through funding from DST-STUTI and other agencies, and own resources for teachers and researchers to build capabilities and enhance research skills. The state of art equipment namely transmission electron microscope, carbon-hydrogen & nitrogen analyzer, high-resolution microscope, HPLC, GC-MS, LC-MS and NMR instruments were purchased to conduct high quality research. The TEM(transmission electron microscope) facility was inaugurated by the Union Minister of Science & Technology Dr. Jitendra Singh on the National Science Day (Feb 28, 2022) Recently, the Ministry of AYUSH, Government of India, has identified JH as a Centre of Excellence in Unani Medicine (Pharmacogony and Pharmacology).

To encourage innovation and its protection Jamia Hamdard has an Intellectual Property Management Cell, which facilitates the patent filing to researchers. MoUs with other leading institutions have encouraged them to share research facilities and expertise for mutual benefits and growth. There is a provision of seed money to the newly appointed faculty in order to work on research thrust areas of their interest. The outcome of the support is measured in terms of publications and projects applied/funded which is monitored externally through experts from other universities and industry. In addition, there are adequate number of post-doctoral students working on areas of societal need.

Additionally, PhD. scholars are getting research support through scholarships. To encourage a sustainable research environment Jamia Hamdard provides incentives to the students and faculty members for performing quality research reflected through high impact factor publications, high citations, and research

accomplishments. All research outputs i.e., publications, reports dissertations and theses are subjected to Plagiarism check through the university approved plagiarism software to uphold the quality.

File Description	Document
Minutes of the Governing Council/ Syndicate/Board of Management related to research promotion policy adoption	View Document
Any additional information	View Document

3.1.2 The institution provides seed money to its teachers for research (average per year, INR in Lakhs)

Response: 195.34

3.1.2.1 The amount of seed money provided by institution to its faculty year-wise during the last five years (INR in lakhs).

2021-22	2020-21	2019-20	2018-19	2017-18
116.98	392.22	296.60	110.98	59.92

File Description	Document
Minutes of the relevant bodies of the University	View Document
Institutional data in prescribed format	View Document
Any additional information	View Document

3.1.3 Percentage of teachers receiving national / international fellowship / financial support by various agencies for advanced studies / research during the last five years.

Response: 10.76

3.1.3.1 The number of teachers who received national / international fellowship / financial support by various agencies for advanced studies / research year-wise during the last five years.

2021-22	2020-21	2019-20	2018-19	2017-18
14	52	45	54	73

File Description	Document
Institutional data in prescribed format	View Document
e-copies of the award letters of the teachers	View Document
Any additional information	View Document

3.1.4 Number of JRFs, SRFs, Post Doctoral Fellows, Research Associates and other research fellows enrolled in the institution during the last five years.

Response: 803

3.1.4.1 The Number of JRFs, SRFs, Post Doctoral Fellows, Research Associates and other research fellows enrolled in the institution year-wise during the last five years.

2021-22	2020-21	2019-20	2018-19	2017-18
150	84	140	175	254

File Description	Document
Institutional data in prescribed format	View Document
Any additional information	View Document

3.1.5 Institution has the following facilities to support research

1. Central Instrumentation Centre
2. Animal House/Green House
3. Museum
4. Media laboratory/Studios
5. Business Lab
6. Research/Statistical Databases
7. Mootcourt
8. Theatre
9. Art Gallery
10. Any other facility to support research

Response: A. 4 or more of the above

File Description	Document
Upload the list of facilities provided by the university and their year of establishment	View Document
Upload any additional information	View Document
Paste link of videos and geotagged photographs	View Document

3.1.6 Percentage of departments with UGC-SAP, CAS, DST-FIST, DBT, ICSSR and other recognitions by national and international agencies (Data for the latest completed academic year)

Response: 66.67

3.1.6.1 The Number of departments with UGC-SAP, CAS, DST-FIST, DBT, ICSSR and other similar recognitions by national and international agencies.

Response: 32

File Description	Document
Institutional data in prescribed format	View Document
e-version of departmental recognition award letters	View Document
Any additional information	View Document

3.2 Resource Mobilization for Research

3.2.1 Extramural funding for Research (Grants sponsored by the non-government sources such as industry, corporate houses, international bodies for research projects) endowments, Chairs in the University during the last five years (INR in Lakhs).

Response: 709.07

3.2.1.1 Total Grants for research projects sponsored by the non-government sources such as industry, corporate houses, international bodies, endowments, Chairs in the institution year-wise during the last five years (INR in Lakhs).

2021-22	2020-21	2019-20	2018-19	2017-18
389.85	102.44	58.95	134.03	23.80

File Description	Document
Institutional data in prescribed format	View Document
e-copies of the grant award letters for research projects sponsored by non-government	View Document
Any additional information	View Document

3.2.2 Grants for research projects sponsored by the government agencies during the last five years (INR in Lakhs).

Response: 12059.13

3.2.2.1 Total Grants for research projects sponsored by the government agencies year-wise during the last five years (INR in Lakhs).

2021-22	2020-21	2019-20	2018-19	2017-18
3370.51	1070.97	1686.65	3746.80	2184.20

File Description	Document
Institutional data in prescribed format	View Document
e-copies of the grant award letters for research projects sponsored by government	View Document
Any additional information	View Document

3.2.3 Number of research projects per teacher funded by government and non-government agencies during the last five years

Response: 0.81

3.2.3.1 Number of research projects funded by government and non-government agencies during the last five years.

Response: 359

3.2.3.2 Number of full time teachers worked in the institution year-wise during the last five years..

Response: 2211

File Description	Document
Supporting document from Funding Agency	View Document
Institutional data in prescribed format	View Document
Any additional information	View Document
Paste Link for the funding agency website	View Document

3.3 Innovation Ecosystem

3.3.1 Institution has created an eco system for innovations including Incubation centre and other initiatives for creation and transfer of knowledge.

Response:

With the vision of "Nurturing of Youth" by training, mentoring and developing them into self-reliant entrepreneurs and turning their ideas into reality through access to professional mentors, collaborative office spaces, and community corporate partners Jamia Hamdard has established a state of the art Centre for Innovation, Incubation and Entrepreneurship (CIIE) in the campus.

CIIE has been created to grow the inner skills of the youth and the academician around the Universities and utilize them to the best of its capabilities to meet the vision of Atamnirbhar Bharat and Make in India Model. This centre is working to tune with the current thrust areas of the Indian Government Initiatives like Make-in-India, Start-up India, Skill India, rural empowerment, Team India etc. On 23rd March, 2022 Hon'ble Minister of State for Education, Dr. Subhas Sarkar Inaugurated the "Centre for Innovation, Incubation and Entrepreneurship (CIIE).

Following Innovative approaches have been demonstrated their innovative products

- Students from computer science demonstrated their life saving AI based drone technology for delivering emergency medicine in remote areas.
- AI based student's attendance system
- A range Nano herbal product with enhance efficacy and bioavailability from Nanomedicine Laboratory lie Nan Curcumin, Nanoneem, Nano thymoquinone, Nano resveratrol, Nano Safran etc.
- Jamia Hamdard has adopted sustainable E-waste management technology along with solar based energy production
- Campus grown Stevia based tea combination products by Department of Biotechnology
- Innovative Unani products by Unani School, recognized as centre of excellence by AYUSH ministry, Government of India
- Honey production is initiated by the Department of Food Technology in the herbal garden at Jamia Hamdard with a total ten wooden beehive boxes. All the steps including initial extraction, dehumidification, liquefaction and mixture, heating, pasteurization followed by crystallization and final packing is conducted at the department.

File Description	Document
Upload any additional information	View Document
Paste link for additional information	View Document

3.3.2 Number of workshops/seminars conducted on Research methodology, Intellectual Property Rights (IPR), entrepreneurship, skill development during the last five years.

Response: 151

3.3.2.1 Total number of workshops/seminars conducted on Research methodology, Intellectual Property Rights (IPR), entrepreneurship, skill development year-wise during the last five years.

2021-22	2020-21	2019-20	2018-19	2017-18
09	31	18	45	48

File Description	Document
Report of the event	View Document
Institutional data in prescribed format	View Document
Any additional information	View Document

3.3.3 Number of awards / recognitions received for research/innovations by the institution / teachers / research scholars / students during the last five years.

Response: 396

3.3.3.1 Total number of awards / recognitions received for *research / innovations* won by institution / teachers / research scholars / students year-wise during the last five years.

2021-22	2020-21	2019-20	2018-19	2017-18
146	55	21	62	112

File Description	Document
Institutional data in prescribed format	View Document
e- copies of award letters	View Document
Any additional information	View Document

3.4 Research Publications and Awards

3.4.1 The Institution ensures implementation of its stated Code of Ethics for research through the following: 1. Inclusion of research ethics in the research methodology course work 2. Presence of Ethics committee 3. Plagiarism check through software 4. Research Advisory Committee

Response: B. 3 of the above

File Description	Document
Code of ethics for Research document, Research Advisory committee and ethics committee constitution and list of members on these committees, software used for Plagiarism check, link to Website	View Document
Any additional information	View Document

3.4.2 The institution provides incentives to teachers who receive state, national and international recognitions/awards 1. Commendation and monetary incentive at a University function 2. Commendation and medal at a University function 3. Certificate of honor 4. Announcement in the Newsletter / website

Response: A.. All of the above

File Description	Document
Institutional data in prescribed format	View Document
e- copies of the letters of awards	View Document
Any additional information	View Document

3.4.3 Number of Patents published / awarded during the last five years.

Response: 85

3.4.3.1 Total number of Patents published / awarded year-wise during the last five years.

2021-22	2020-21	2019-20	2018-19	2017-18
14	33	20	9	9

File Description	Document
Institutional data in prescribed format	View Document
Any additional information	View Document

3.4.4 Number of Ph.D's awarded per teacher during the last five years.

Response: 1.65

3.4.4.1 How many Ph.D's are awarded within last five years.

Response: 321

3.4.4.2 Number of teachers recognized as guides during the last five years

Response: 194

File Description	Document
Institutional data in prescribed format	View Document
Any additional information	View Document
URL to the research page on HEI web site	View Document

3.4.5 Number of research papers per teachers in the Journals notified on UGC website during the last five years

Response: 13.67

3.4.5.1 Number of research papers in the Journals notified on UGC website during the last five years.

2021-22	2020-21	2019-20	2018-19	2017-18
733	1273	1371	1034	1634

File Description	Document
Institutional data in prescribed format	View Document
Any additional information	View Document

3.4.6 Number of books and chapters in edited volumes/books published and papers published in national/ international conference proceedings per teacher during last five years

Response: 2.4**3.4.6.1 Total number of books and chapters in edited volumes/books published and papers in national/ international conference proceedings year-wise during last five years**

2021-22	2020-21	2019-20	2018-19	2017-18
106	306	252	192	207

File Description	Document
Institutional data in prescribed format	View Document
Any additional information	View Document

3.4.7 E-content is developed by teachers :

1. For e-PG-Pathshala
2. For CEC (Under Graduate)
3. For SWAYAM
4. For other MOOCs platform
5. Any other Government Initiatives
6. For Institutional LMS

Response: A. Any 5 of the above

File Description	Document
Institutional data in prescribed format	View Document
Give links or upload document of e-content developed	View Document
Any additional information	View Document

3.4.8 Bibliometrics of the publications during the last five years based on average citation index in Scopus/ Web of Science or PubMed**Response:** 10.96

File Description	Document
Bibliometrics of the publications during the last five years	View Document
Any additional information	View Document

3.4.9 Bibliometrics of the publications during the last five years based on Scopus/ Web of Science - h-index of the Institution**Response:** 55

File Description	Document
Bibliometrics of publications based on Scopus/ Web of Science - h-index of the Institution	View Document
Any additional information	View Document

3.5 Consultancy**3.5.1 Institution has a policy on consultancy including revenue sharing between the institution and the individual and encourages its faculty to undertake consultancy.****Response:**

Jamia Hamdard encourages faculty to expand and secure the research profile of the university utilizing her/his current research knowledge and experience. The capabilities of faculty, execute the best of academia and industry partnership to devise innovative solutions to scientific problems. The partnership promotes the translational research activities, and innovative technology development and its transfer to industry for better utilization in sustainable development and intellectual property support.

Keeping the above goal, Jamia Hamdard has a well-defined encouraging consultancy policy document with revenue sharing between institution and investigator(s) implemented through the Director (Research and Development Cell). The Principal investigators will undertake consultancy projects keeping in view any conflict of interest and ensuring proper protection of intellectual property rights (IPR). A provision of signing an agreement/memorandum of understanding (MoU) detailing all clauses of project is mandatory. The agreement/MoU is signed by the Registrar on behalf of Jamia Hamdard and the authorized signatory of the other party. Jamia Hamdard has policy of 'Institutional Overheads' in all consultancy projects as per the funding agencies with sharing of overheads as per Jamia Hamdard policy in this regard. All sanctioned funds received in the name of Jamia Hamdard. Furthermore, in order to encourage faculty members to undertake Consultancy Projects, Jamia Hamdard shares consultancy charges in the ratio of 30:70 (Jamia Hamdard and Project investigator(s)). The consultancy is available for a wide range of areas that need improvement, upgradation, and advancement. All expenditures, procurements and purchases following GFR 2017 in place as amended time to time. On completion of the consultancy project, PI need to submit an official completion report with details of the objectives achieved along with utilization certificate and statement of expenditure.

File Description	Document
Upload soft copy of the Consultancy Policy	View Document
Upload minutes of the Governing Council/ Syndicate/Board of Management related to consultancy policy	View Document
Upload any additional information	View Document
Paste URL of the consultancy policy document	View Document

3.5.2 Revenue generated from consultancy and corporate training during the last five years (INR in Lakhs).

Response: 522.4

3.5.2.1 Total amount generated from consultancy and corporate training year-wise during the last five years (INR in lakhs).

2021-22	2020-21	2019-20	2018-19	2017-18
2.8	344.51	50.5	38.25	86.34

File Description	Document
Institutional data in prescribed format	View Document
Audited statements of accounts indicating the revenue generated through consultancy	View Document
Any additional information	View Document

3.6 Extension Activities

3.6.1 Extension activities in the neighbourhood community in terms of impact and sensitising students to social issues and holistic development during the last five years.

Response:

The history of Jamia Hamdard (JH) begins with the establishment of a small Unani clinic in the year 1906 by Hakeem Hafiz Abdul Majeed. He gave the name “Hamdard” to the institution, which means “sympathy for all and sharing of pain”. Since its inception Hamdard has focused primarily on creating awareness and providing services to the community. It has consistently organized training programmes, workshops, seminars and other community outreach programmes to sensitize the students and neighbourhoods on social, societal and community issues including health and hygiene, sanitation, reducing water-wastage.

JH has actively participated in several flagship programmes of the Govt. of India including Unnat Bharat Abhiyan, Smart India Hackathon, Yoga Day, Institution Innovation Council etc. There are various extension and outreach activities being conducted include:

Unnat Bharat Abhiyan

Under this programme JH has organised several activities to create awareness among the faculty, students, non-teaching staff, neighborhoods and other stakeholders about the various societal and community specific issues including healthcare, hygiene, sanitation, education, employment etc. A house hold survey of in-depth “Need analysis” of the community has been conducted. JH has collaborated with Reaching Sky Foundation, a Delhi based NGO and Business and Employment Bureau (BEB) as the technical partner for UBA. The various villages adopted under UBA include Chattarpur, Kalkaji, Saidul Azaib, Deoli, and Mehrauli. Other collaborators of UBA include the Hamdard National Foundation, Prajna Foundation and Sewa Bharti. NSS volunteers contribute to these extension activities.

Skill Based Courses

JH in collaboration with BEB has organized several skill-based courses for the weaker section of the society providing hands-on training on Sewing and tailoring etc.

Health and Hygiene Awareness Programmes

The Hakeem Abdul Hameed Centenary Hospital (HAHC) provides affordable healthcare facilities to the neighbourhood community including staff and students of JH. The school of Nursing, Pharmacy and Unani medicine consistently organize various health awareness programmes for the neighbourhood where the students and teachers actively participates and sensitize the community on topics like general healthcare, orthopaedic care for the elderly, eye care, importance of breastfeeding, blood and organ donation, mental health and hygiene, nutrition deficiency among youth, air and water pollutions and associated diseases.

Legal and Cyber awareness programmes

The Hamdard Institute of Legal Studies organizes awareness programmes including workshops, seminars, training programmes and nukkad-nataks etc. for the students, teachers and neighbourhoods in collaboration with Delhi Police, Delhi Legal Service Authority etc. on topic like cyber security, domestic violence, cyber bullying, and legal aids.

National skills training centre – DAKSH

The School of Nursing and Allied Health JH in collaboration with the Ministry of Health and Family Welfare and Liverpool School of Tropical Medicine (LSTM), United Kingdom has set up a National Skills Training Centre - Daksh in the University Campus. The Centre for Maternal Newborn Health (CMNH), Liverpool School of Tropical Medicine (LSTM), in partnership with Government of India has successfully completed the 1st phase of its training programme “Making it Happen”, for public healthcare service providers. The “Making it Happen programme in India focuses on training in Reproductive, Maternal, Newborn, Child and Adolescent Health (RMNCH+A) in India, through “Skills Labs”.

File Description	Document
Paste link for additional information	View Document

3.6.2 Number of awards received by the Institution, its teachers and students from Government /Government recognised bodies in recognition of the extension activities carried out during the last five years

Response: 31

3.6.2.1 Total number of awards and recognition received for extension activities from Government/ Government recognised bodies year-wise during the last five years.

2021-22	2020-21	2019-20	2018-19	2017-18
1	3	9	6	12

File Description	Document
Institutional data in prescribed format	View Document
e-copy of the award letters	View Document
Any additional information	View Document

3.6.3 Number of extension and outreach programs conducted by the institution through NSS/NCC, Government and Government recognised bodies during the last five years

Response: 169

3.6.3.1 Number of extension and outreach programs conducted by the institution those through NSS/NCC, Government and Government recognised bodies during the last five years

2021-22	2020-21	2019-20	2018-19	2017-18
15	61	41	24	28

File Description	Document
Reports of the event organized	View Document
Institutional data in prescribed format	View Document
Any additional information	View Document

3.6.4 Average percentage of students participating in extension activities listed at 3.6.3 above during the last five years**Response:** 21.42**3.6.4.1 Total number of students participating in extension activities listed at 3.6.3 above year-wise during the last five years.**

2021-22	2020-21	2019-20	2018-19	2017-18
887	2288	1513	1124	1888

File Description	Document
Report of the event	View Document
Institutional data in prescribed format	View Document
Any additional information	View Document

3.7 Collaboration**3.7.1 Number of Collaborative activities for research, Faculty exchange, Student exchange/ internship per year****Response:** 795.6**3.7.1.1 Total number of Collaborative activities with other institutions / research establishment / industry for research and academic development of faculty and students year-wise during the last five years.**

2021-22	2020-21	2019-20	2018-19	2017-18
1169	950	671	497	691

File Description	Document
Institutional data in prescribed format	View Document
Copies of collaboration	View Document
Any additional information	View Document

3.7.2 Number of functional MoUs with institutions/ industries in India and abroad for internship, on-the-job training, project work, student / faculty exchange and collaborative research during the last

five years.

Response: 52

3.7.2.1 Number of functional MoUs with institutions/ industries in India and abroad for internship, on-the-job training, project work, student / faculty exchange and collaborative research year-wise during the last five years.

2021-22	2020-21	2019-20	2018-19	2017-18
2	1	3	13	33

File Description	Document
Institutional data in prescribed format	View Document
e-copies of the MoUs with institution/ industry	View Document
Any additional information	View Document

Criterion 4 - Infrastructure and Learning Resources

4.1 Physical Facilities

4.1.1 The institution has adequate facilities for teaching - learning. viz., classrooms, laboratories, computing equipment, etc.

Response:

The delivery of teaching-learning is a multi-modal process involving the interaction and engagement between the students and the teachers in classrooms, laboratories, and information centers. The University has 9 academic buildings and 121 classrooms/tutorial rooms/seminar halls with ICT facility. University also has state-of-the-art laboratories and ubiquitous computing facilities.

Classrooms

University imparts education through classrooms equipped with modern facilities. These classrooms are connected to network through Wi-Fi and are equipped with ICT facilities. Jamia Hamdard strictly follows the norms laid down by the respective statutory bodies. For example, in Medicine, as per the MCI norms, the UG classrooms accommodate 100 students and PG classrooms accommodate more than 13 students. Similarly, in School of Engineering, the UG and PG classrooms can accommodate 60 and 30 students, respectively. There is also a cluster of much larger classrooms that helps in conducting combined lectures, auditorium-style seminar halls, and group meeting and discussion rooms.

Teaching & Research Laboratories

The university has around 100 states of the art laboratories for hands-on training of undergraduates, post-graduate, and Ph.D. students. UG and PG labs are well equipped and help in conducting the practicals that are part of the curriculum. These labs are managed by trained technical staff and lab attendants. In many schools, PG labs also help dissertation students to carry out their M.Sc. thesis work. Apart from UG and PG labs, there are also many research labs that help Ph.D. and post-doctoral students in carrying out research work. These research labs are under the supervision of faculty members and are funded by Research Grants from different funding agencies like UGC, DST, DBT, ICMR and others. The infrastructure for research in the university is also supported by prestigious grants like UGC-SAP, DST-FIST, AICTE and DST-PURSE. Schools also have Departmental Instrumentation Facility (DIF) and Centre Instrumentation Facility (CIF). These facilities have high-end instruments and are also open to the researchers from other departments. There are also separate instrumentation facilities for Bioinformatics, NMR, TEM, and LC-MS. After proper approval, researchers from outside the university can also avail the instrumentation facilities. University also has a Central Animal House facility that helps in conducting experiments on animal models.

University also has collaborated with corporate giants like Hilleman Laboratories, Sun Pharma, and BD Biosciences in setting up of industry sponsored laboratories. These research facilities train our students and provide technical, and experimental help based on sophisticated instruments. University also offers a Ph.D. programme in pharmaceutical medicine which is being offered in collaboration with Sun Pharma.

Computing Equipment

Jamia Hamdard provides ubiquitous access to information and network services. All the academic blocks, laboratories, and hostels are all connected with Wi-Fi with access to the internet over multiple links through multiple ISPs. A robust tiered network enables connectivity without compromising security and confidentiality for all user data. The computing labs cater to several cutting-edge research areas such as Big Data Analytics and Machine learning. The servers are enabled with the latest virtualization software. The data center also hosts a High-Performance Computing System.

File Description	Document
Upload any additional information	View Document
Paste link for additional information	View Document

4.1.2 The institution has adequate facilities for cultural activities, yoga, games and sports (indoor & outdoor); (gymnasium, yoga centre, auditorium, etc.,)

Response:

Sports and cultural activities

Jamia Hamdard provides a vibrant sports and cultural environment for the holistic growth of students. Under the supervision of Dean Students' Welfare, Sports Secretary, Cultural Coordinator and presidents and members of different Clubs help students in nurturing their co-curricular talent. These clubs include Mental Health Club, Film and Drama Club, Literary Club, Sports Club, Yoga Club, Music Club, Eco Club and Mountaineering & Trekking Club.

Clubs of Jamia Hamdard



University has 05 well equipped auditoriums for students' cultural events. Inter-school sports tournaments (Hamdard Sports Meet) and Literary & Cultural Events are organized annually. Various other inter and intra-school tournaments are also organized by the University throughout the year. Teams of Jamia Hamdard also participate in sports & cultural activities at national, regional, and zonal level events. Jamia Hamdard has organized zonal and national tournaments like North Zone Inter University Basketball Tournament for men in 2018 that included 60 teams of major universities. This reflects the capability and excellent sports infrastructure available on the campus. To promote sports, university also offers a 5% relaxation in the minimum eligibility criteria for admission for sports persons. Sports facilities are open to all the students and staff with around 1000 users/day while some facilities like gym are open only to members with around 30-45 users/days.

Jamia Hamdard has indoor and outdoor sports facilities on campus. The sports complex incorporates the following facilities:

1. One cricket ground (137m/150m, equipped with floodlights for night matches.)
2. One basketball synthetic court (5442 sq ft, equipped with floodlights)
3. One volleyball courts (18 m long/9 m wide, outdoor)
4. Two badminton courts (30.8m long/12.2 m wide, indoor courts)
5. Fitness center/Gym (1000 sq. ft., indoor)
6. Football ground (24624 sq. ft.)
7. Athletic track (400 meter, multipurpose)
8. Long jump pit
9. Shot put sector
10. Discuss throw sector
11. Table Tennis Hall (18m long/10m wide, two)
12. Carrom and Chess boards (indoor)
13. Billiards Table

NSS and NCC

The NSS volunteers participate in various awareness programs such as Pulse Polio Immunization camps, awareness about Hepatitis-B, DPT and BCG immunization, HIV/AIDS, STD, the importance of cleanliness, and illiteracy eradication program, plantation, and related activities. NSS volunteers organize a Blood Donation Camp every year. The number of NSS volunteers in Jamia Hamdard is around two hundred.

Jamia Hamdard has 36 boys (7DBN) and 49 girls (3DGBN) NCC cadets. Most of the cadets have completed B or C certification and attended various CATC, Trekking National Camp, Army Attachment, and Other National Camps. Our cadets actively participate in Blood Donation camps, Jal Shakti Abhiyan, and Swachta Pakhwada Mission of the Government of India.

Yoga

Jamia Hamdard offers yoga and meditation sessions that help students and staff to develop mindfulness and self-awareness. Yoga and meditation facility is provided to students and staff of the university. Every year on 21st June, university celebrates international yoga day. We have a dedicated yoga club which organizes yoga events at the school and university level.

There are large and small auditoriums to hold cultural events.

File Description	Document
Upload any additional information	View Document
Geotagged pictures	View Document
Paste link for additional information	View Document

4.1.3 Availability of general campus facilities and overall ambience

Response:

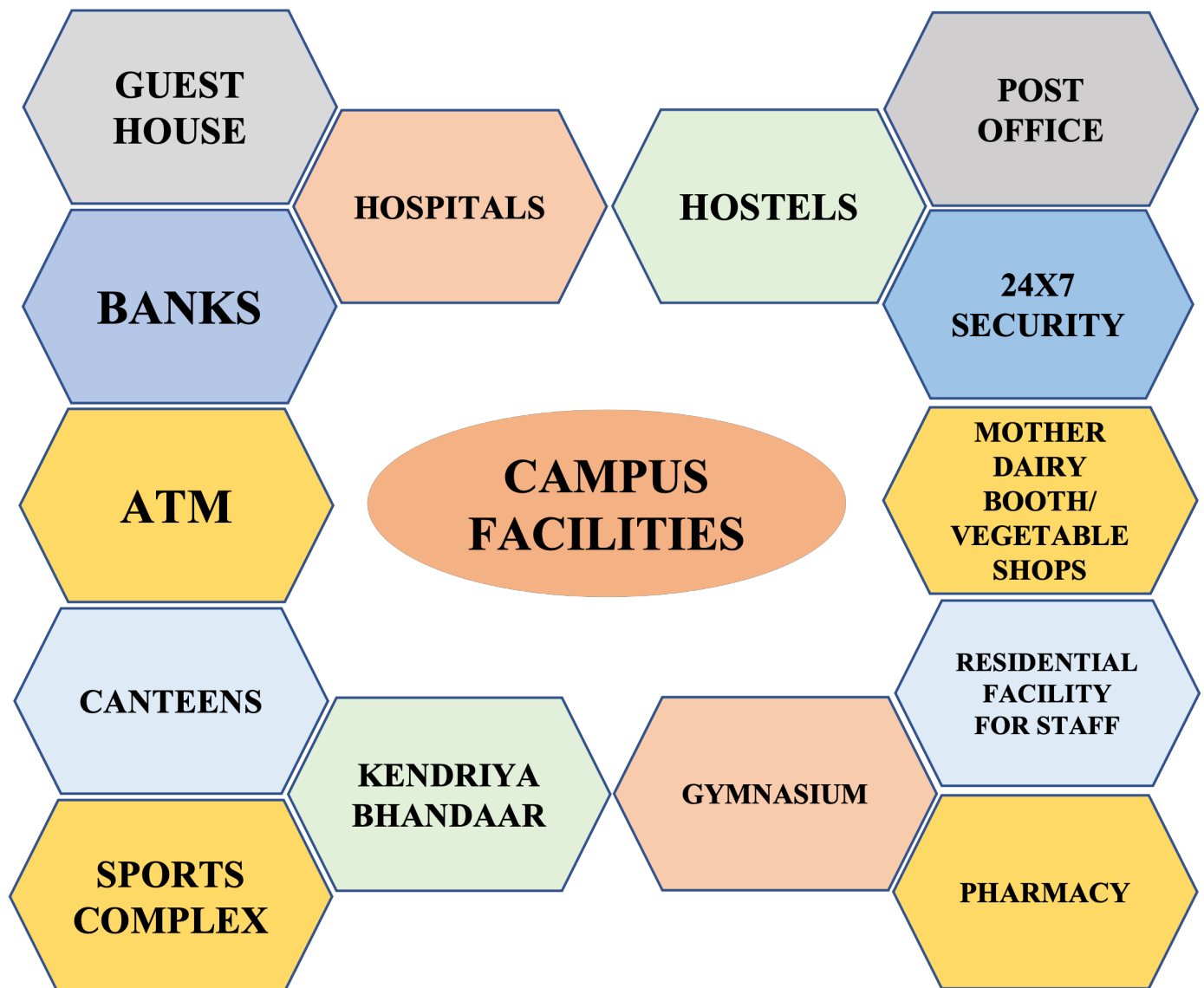

Jamia Hamdard provides excellent campus facilities for both the students and staff members. It has many hostels for boys and girls of different programs along with residential complexes for teaching and non-teaching staff of the university. In addition, within the campus and outside the campus lodging facility is also available for the Vice-chancellor, Pro-Vice Chancellor, Registrar and Finance Officer. The campus has 05 well equipped auditoriums, for holding seminars/conferences/workshops. The buildings in the campus have ramps, lifts and toilets for differently-abled students. Campus offers facilities for the students such as canteens with the availability of different foods and beverages options. These canteens (with

different names like Pharmacy Canteen, Classic Café, Café Cozy, FrndZone, foodhood, chachu canteen, and Recharge Zone) are located at different corners of the campus and caters to the need of both students and teachers at subsidized rates. The campus also has a co-operative store (Kendriya Bhandar) that provides groceries and various stationary items at affordable rates. To ensure stress free stay of students at the campus, university also has an array of basic amenities like laundry facility, Mother dairy, fruits, and vegetable shop. University campus also has dedicated branch of Bank of India and J&K Bank along with ATM kiosks of three different banks. The campus also houses a beauty parlour and barber shop. It also has a Post Office managed by India Post. University has a guest house popularly known as Scholars House and another VIP guest house. These guest houses provide safe and cost effective accommodation options for official and personal guests of staff members. The campus has also well-established botanical garden harboring variety of herbal and medicinal plants. Herbal garden is also visited by students for activities related to education and research. For the overall development of students and helping them in maintaining the healthy lifestyle, campus has an indoor stadium for table tennis and badminton and on-campus gym for a handy workout in between or after the classes. University sports complex also has basketball court, volleyball court, football, and cricket ground with day-night match facility. The university cricket ground also hosts tournaments organized by corporates and cricket clubs of Delhi NCR. Jamia Hamdard has two hospitals, Majeedia Unani Hospital and HAHC Hospital to provide medical support to needy students, faculty and staff. Further, it has empanelled various super specialty hospitals to provide medical facilities to its staff. The university has a pharmacy associated with the hospital along with Unani medicine outlets like Majeedia Unani Pharmacy and Hamdard Wellness outlet. The campus is guarded 24x7 under the supervision of proctorial team, security in-charge and security guards. Vehicle movements in the campus is also assisted/monitored by the security guards who help in recording the data of entry/exit at every gate and implementing the speed limit within the campus. Campus also has a day care centre which provides care to children of the staff and students from infancy to school going age. The facilities and environment provided by the university attracts many students from different corners of the country and abroad.

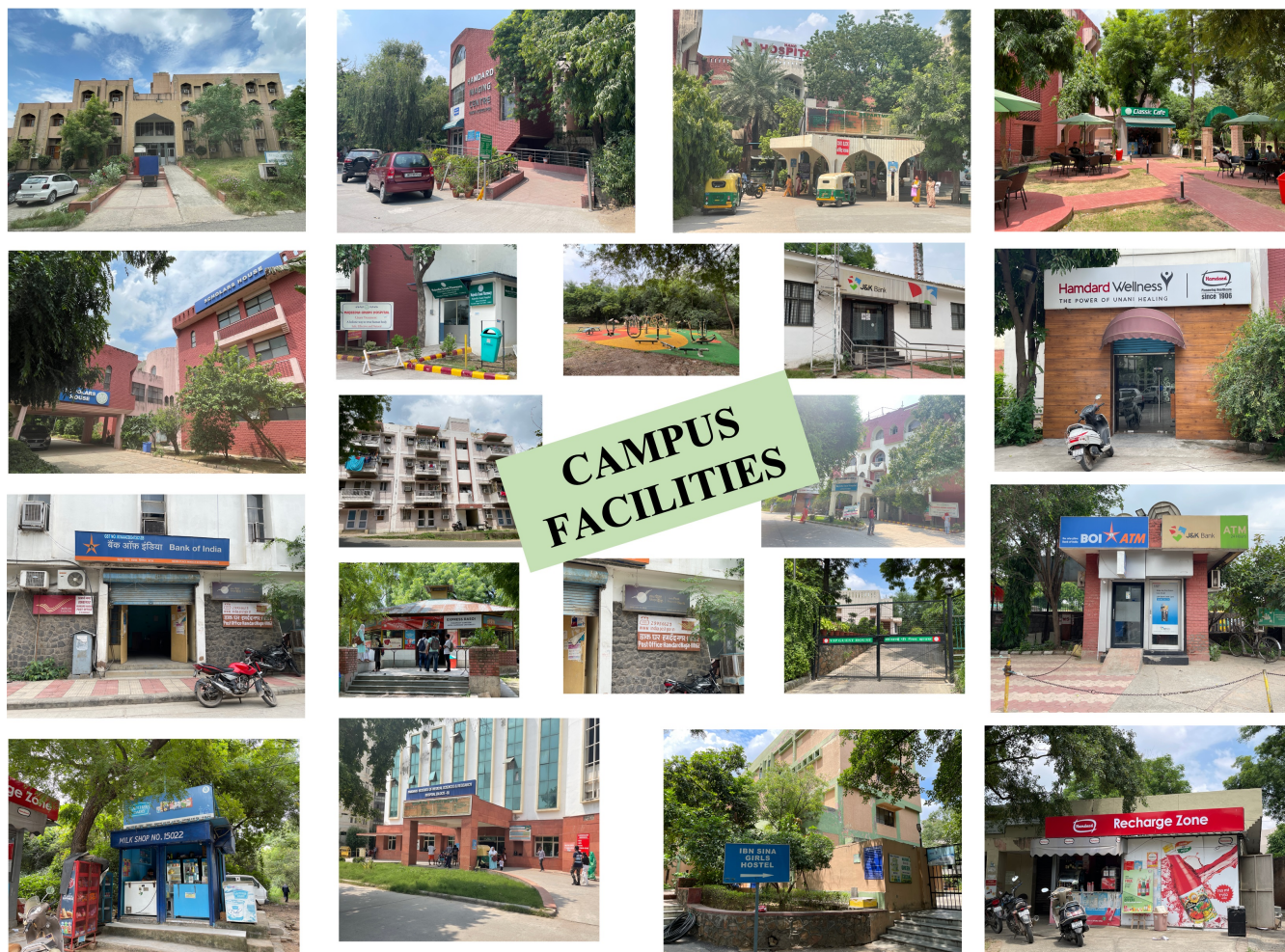

File Description	Document
Upload any additional information	View Document
Paste link for additional information	View Document

4.1.4 Average percentage of expenditure for infrastructure augmentation excluding salary during the last five years (INR in Lakhs)

Response: 8.93

4.1.4.1 Expenditure for infrastructure augmentation, excluding salary during the last five years (INR in lakhs)

2021-22	2020-21	2019-20	2018-19	2017-18
184.00	414.00	360.26	631.66	1091.42

File Description	Document
Upload audited utilization statements	View Document
Institutional data in prescribed format	View Document

4.2 Library as a Learning Resource

4.2.1 Library is automated using Integrated Library Management System (ILMS) and has digitisation facility

Response:

Library computerization

The library has undertaken computerization of its house-keeping activities based on the popular library management system, LIBSYS, since 2004. Keeping in view the nature of the collection which also consist of a large number of non-European printed materials, bibliographic databases in Unicode compliant standard have been developed. Now, a variety of bibliographic databases, such as database for printed books, thesis and CD-ROMs are available in different languages like English, Urdu, Hindi, Persian and Arabic. These databases can be easily accessed 24x7 throughout the campus and beyond on the intranet and internet topography. All library members are provided bar-coded library cards with category specific privileges for borrowing materials from any issue counter within the library system. The RFID based circulation system has also been introduced since 2018-19 and integrated with the already running LIBSYS software of the HMS Central Library. This new technology helps library users to automatically check-out and check-in the library materials. The library is also benefitted as the system provides protection against theft as well as misplacement of books. The library has also introduced Biometric Fingerprints Access and Charging/Discharging control system in the Central Library to facilitate real-time record of footfalls in the library. The Central Library also undertakes compulsory checking of all research papers and doctoral theses through the 'URKUND' software for which online link have been provided by the INFLIBNET. Process has been initiated to subscribe to TURNIT/i-authenticate plagiarism check softwares. The library offers periodic orientation programs and on-demand training programs to access the different databases and e-resources. Some of the library services that have been automated include, Charging/Discharging of documents, Book Bank service, Inter-library loan service (through DELNET), Documents delivery service (DDS), Electronic theses and dissertation (ETD) service, Short-Range and Long-Range Reference Service, Anti-plagiarism check (through web tools URKUND), and providing In house digital content through Intranet.

Lamination and Digitization activities

The library is undertaking regular conservation and preservation activities for protecting and increasing the shelf-life of the manuscripts available in the Manuscript Division. Digitization of rare printed books are also undertaken to facilitate long-term preservation as well easier global access of these valuable documents over the web. Most of these archival activities are undertaken with technical and financial supports from various government agencies such as National Mission for Manuscripts (NMM) and National Archives of India (NAI). Hundreds of depilated rare books which could be not handled by naked hands have been given fresh life for posterity through digitization and archival binding under the NAI projects. The National Mission for Manuscripts (NMM), another specialized body under the Ministry of

Culture devoted to resurrection of old Indian arts and manuscripts has been engaged to digitize the majority of manuscript collection. Handsome grants have been received through the UGC on the recommendation of the INFLIBNET for the purpose of (i) uploading the back-files of Ph.D. theses to the Shodhganga ETD repository; (ii) purchasing of over-head scanner and server for setting-up the in-house ETD laboratory to support digitization process.

File Description	Document
Upload any additional information	View Document
Paste link for additional information	View Document

4.2.2 Institution has access to the following: 1. e-journals 2. e-ShodhSindhu 3. Shodhganga Membership 4. e-books 5. Databases 6. Remote access to e-resources

Response: A. Any 4 or more of the above

File Description	Document
Upload any additional information	View Document
Institutional data in prescribed format	View Document

4.2.3 Average annual expenditure for purchase of books/ e-books and subscription to journals/e-journals during the last five years (INR in Lakhs)

Response: 29.18

4.2.3.1 Annual expenditure for the purchase of books and journals including e-journals year-wise during last five years (INR in Lakhs)

2021-22	2020-21	2019-20	2018-19	2017-18
35.47	13.77	33.95	50.03	12.7

File Description	Document
Institutional data in prescribed format	View Document
Audited statements of accounts	View Document

4.2.4 Percentage per day usage of library by teachers and students (foot falls and login data for online access) during the latest completed academic year

Response: 8.2

4.2.4.1 Number of teachers and students using library per day over last one year

Response: 799

File Description	Document
Details of library usage by teachers and students (Library accession register, online accession details to be provided as supporting documents)	View Document
Any additional information	View Document

4.3 IT Infrastructure**4.3.1 Percentage of classrooms and seminar halls with ICT - enabled facilities such as LCD, smart board, Wi-Fi/LAN, audio video recording facilities. (Data for the latest completed academic year)**

Response: 100

4.3.1.1 Number of classrooms and seminar halls with ICT facilities

Response: 121

File Description	Document
Upload any additional information	View Document
Institutional data in prescribed format	View Document
Paste link for additional information	View Document

4.3.2 Institution has an IT policy, makes appropriate budgetary provision and updates its IT facilities including Wi-Fi facility**Response:**

Jamia Hamdard maintains a proper system for upgradation of its IT infrastructure with pace of the time and advancement in the field of IT. Most of the IT resources are covered under Annual Maintenance Contract (AMC). Any critical problem is addressed on emergency basis. Ageing policy of IT items are strictly followed to replace/upgrade the IT resources once its recommended years of use are over.

The IT policy of the Jamia Hamdard ensures authenticity of procurement, installation, maintenance, upgradation/renewal of hardware and software. It covers the policies for the fair usage of Internet in campus and other available IT facilities and networking environment.

JH has adequate budgetary provision in its annual budget for upgradation of its IT infrastructure.

- Budgetary provisions are made under recurring grants to maintain all the existing ICT infrastructure for smooth functioning of all the ICT enabled services.

- Appropriate budgetary provisions under capital head are kept for upgradation and augmentation of ICT infrastructure. On an average 45-50 lakhs per year are allocated for procurement and maintenance of IT infrastructure.
- Emergent budgetary provisions are maintained to meet the emergent need for solution of any problem.
- Budgetary provision under capital grant is allocated for adaptation of ICT solutions from time to time.

Cyber Security Features:

- Old UTM models Cyberoam CRX-500 and Cyberoam 1500 iNG which were procured in 2006 and 2014 are upgraded with Sophos XG650 Firewall UTM in 2021 for anti-spamming, virus scanning, firewall, NATTING, user authentication, IPS scanning etc.
- Trend Micro - Antivirus plus Security Software are installed on all computers.

Networking Infrastructure:

- Entire campus is enabled with Internet speed of 1 Gbps provided by NKN, Govt. of India, and 100 Mbps backup line from Spectranet, connected through fiber optical cable.
- Expanded network capabilities as per current demand and usage to serve around 6000 Wi Fi users and 2500 networking points spreading around our 91.6-acre campus. At present JH has 305 Wireless Access Points, upgraded routers to Cisco 5760 - WLAN Controller in HA mode, Cisco 4500 L3 Switch, Cisco -3650 / 2960 / 2950 L2 Switches (55 Nos.)
- Storage is upgraded to HP MSA 2050 (45 TB) storage and SAN switches clustering to connect servers and MSA

Upgradation of Hardware / Software / other Facilities:

- Replaced old low configuration physical servers with high end server to make server clusters from HP ProLiant - DL580G5/ DL580G7 / DL180G6, Dell R530 to HP ProLiant DL360 Gen10 Plus (5 servers, 120 core)
- Upgraded and deployed virtual infrastructure with latest VMware 7.0
- Upgraded desktop systems (225 Nos.) from old Pentium/dual core processors with high performing i5 and i7 based processors
- Developed high-end data centre
- Design, development, and implementation of University ERP System is under process
- Signed Contract with CISCO for the upgradation of CISCO networking equipment
- Signed contract with major mobile operators for the installation of signal boosting towers and equipment to get mobile internet connectivity
- Has subscription of Google Workspace for education to implement Gmail, Google Meet, and other related services
- Design and development of new CMS based website is under process

JAMIA HAMDARD OFC NETWORK

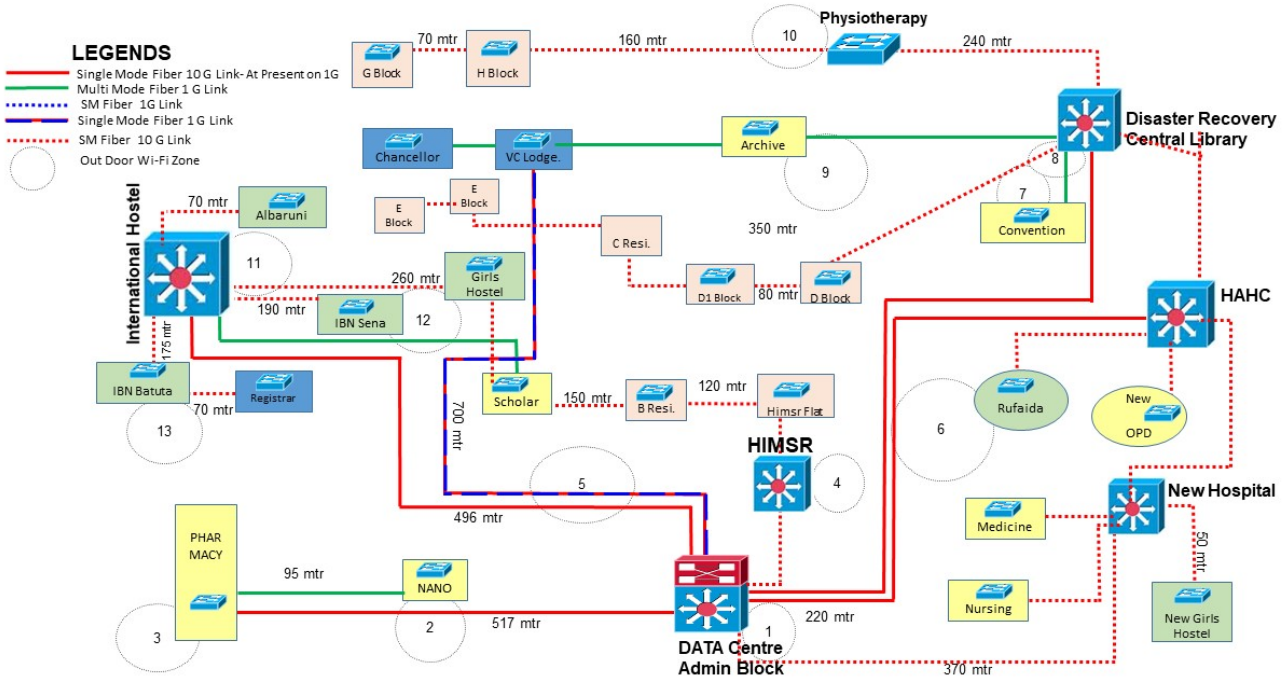

File Description	Document
Upload any additional information	View Document
Paste link for additional information	View Document

4.3.3 Student - Computer ratio (Data for the latest completed academic year)

Response: 7:1

File Description	Document
Upload any additional information	View Document
Student – computer ratio	View Document

4.3.4 Available bandwidth of internet connection in the Institution (Leased line)

Response: A. ?1 GBPS

File Description	Document
Upload any additional information	View Document
Details of available bandwidth of internet connection in the Institution	View Document

4.3.5 Institution has the following Facilities for e-content development

1. Media centre
2. Audio visual centre
3. Lecture Capturing System(LCS)
4. Mixing equipments and softwares for editing

Response: B. 3 of the above

File Description	Document
Upload any additional information	View Document
Institutional data in prescribed format	View Document
Links of photographs	View Document

4.4 Maintenance of Campus Infrastructure**4.4.1 Average percentage expenditure incurred on maintenance of physical facilities and academic support facilities excluding salary component during the last five years**

Response: 46.44

4.4.1.1 Expenditure incurred on maintenance of infrastructure (physical facilities and academic support facilities) excluding salary component year-wise during the last five years (INR in lakhs)

2021-22	2020-21	2019-20	2018-19	2017-18
1589.00	2399.00	2612.00	3434.00	2544.00

File Description	Document
Upload any additional information	View Document
Institutional data in prescribed format	View Document
Audited statements of accounts	View Document

4.4.2 There are established systems and procedures for maintaining and utilizing physical, academic and support facilities - laboratory, library, sports complex, computers, classrooms etc.

Response:

Jamia Hamdard has well defined systems and procedures for maintaining and utilizing physical, academic and support facilities. The university is managed by top committees like Board of Management, Academic Council, Finance Committee, and Planning and Monitoring Board. Overall maintenance of the university buildings, classrooms, sports complex, hostels, guest house, gardens and lawns are taken care of by the Engineering and Maintenance (E&M) department. The E&M department has a team that includes Executive Engineer, Junior Engineer, and other staff (Civil and Electricals). Housekeeping and upkeep of University Campus is also supported by horticulture and house-keeping department. Proper requisition forms are available for availing the facilities from E&M Department. Estate officer is appointed to look after the infrastructural requirements of various departments and also manage the allotment of campus accommodations. Provost is the in-charge of hostel maintenance.

The process of purchase and procurement is managed by the Central Purchase Section. Local purchase committees are formed at School level to look into the procurement of items of below 2.5 L, as per the GFR2017 rules. Central Purchase Committee looks into the purchase of higher values as per the GFR2017/University rules. Central store is responsible for keeping the records of the procured items. The purchase and billing process is automated with the help of University Management System (UMS). The finance of the university is managed by Finance and Accounts section supervised by the Finance Officer, Assistant Finance Officer and other staff.

CLASSROOMS

The comprehensive infrastructure of the institution is constituted by elementary features like buildings, demonstration rooms and seminar rooms as well as advanced facilities like ICT-enabled Lecture Theatres. Head of the Department is in charge of the functioning and maintenance of the classrooms of their department. The maintenance work is done by E&M Department of the university. The Cluster Classrooms facility is available in the Central Library building and the facilities can be availed by various Departments as per their requirements. The Medical College HIMSR also has college level lecture theatre committee that helps to supervise and maintain the lecture halls and the respective sophisticated equipment facilities of the Department.

LABORATORIES

The Heads of the Departments supervise their undergraduate, postgraduate and research laboratories. The Heads of the Departments intend their laboratory requirements as well as maintenance related requirements through proper channel. All the stocks and financial accounts of the laboratories are maintained by the Lab in-Charge and are supervised regularly by the Heads of the Department. School level Central Laboratories (such as CIF) have a faculty-in charge and works under the supervision of Dean.

LIBRARY

The Library Committee with the University Librarian as Member Secretary, supervise the functioning and maintenances of the library. The committee is responsible for procuring books, journals and other materials. The committee recommends the purchases which are finalized and approved through proper channel and sent to Finance Section. The school libraries are supervised and managed by the Dean of the school. University librarian supervises proper management of library functioning like proper organization of books, weeding out of old titles, schedule of issue/ return of books etc. with the help of library staff. To ensure return of books, 'no dues' from the library is mandatory for students before passing out of the university. The library is computerized and provides free access to e-resources and e-journals to the

students and faculty.

SPORTS COMPLEX

The sports infrastructure is maintained by the university and necessary steps are taken periodically by the authorities to develop the sports facilities for the students. University level Sports Club committee has been formed that includes Cricket Club, Football Club, Badminton and Table Tennis Club, Chess and Carrom Club, Athletics Club, Basketball and Volleyball Club. Faculty members from different schools are part of the committee and help in organizing sports related activities like sports week, intra-university tournaments and inter-university tournaments.

MAINTENANCE OF COMPUTERS, INTERNET AND WI-FI

There are good number of desktop computers, laptop, LCD projectors, printers, photocopying machines, and Scanner machines in the university. Computer centre is looking after the purchase and maintenance of licensed software. Jamia Hamdard is fully equipped with internet facility, Wi-Fi devices excess point, and wi-fi router in each academic and residential blocks of the University campus. Jamia Hamdard provides the internet via 100 mbps LAN line through MTNL service provider. The internet, Wi-Fi system is maintained by a team of supporting technical staff (system analyst, programmer, faculty in-charge) under the supervision of Head, Computer Centre.

CAMPUS AND OTHER PHYSICAL FACILITIES Hostel and Mess Facility: Jamia Hamdard has separate hostels for boys and girls. The hostel management team includes Provost, Dy. Provost and Wardens. The hostel mess runs on cooperative system and is monitored by wardens under the supervision of Provost and Deputy Provost /chief warden.

Canteen: Proper hygienic food is served in all canteens. Estate Officer supervises the overall functioning and contract of the canteen and serves as member secretary of canteen committee of Jamia Hamdard.

Medical: The teaching and non-teaching staff are provided the healthcare and dispensary facility as per the government schemes. The staff can avail medical facilities at HAHC hospital, Majeedia Unani Hospital and Rehabilitation Centre located on the campus. Jamia Hamdard has also signed MoUs with various leading hospitals in Delhi where employees can avail hospital facilities at CGHS rates.

Security System: Jamia Hamdard has well established security system through External Agency. The agency is providing the security with human resources and electronic equipment.

EPBS System: The institute has well established EPBS system with telephone connections and extensions and is maintained by skilled staff under the supervision of Executive Engineer.

File Description	Document
Upload any additional information	View Document
Paste link for additional information	View Document

Criterion 5 - Student Support and Progression

5.1 Student Support

5.1.1 Average percentage of students benefited by scholarships and freeships provided by the institution, Government and non-government agencies (NGOs) during the last five years (other than the students receiving scholarships under the government schemes for reserved categories).

Response: 5.86

5.1.1.1 Number of students benefited by scholarships and free ships provided by the institution, Government and non-government bodies, industries, individuals, philanthropists during the last five years (other than students receiving scholarships under the government schemes for reserved categories)

2021-22	2020-21	2019-20	2018-19	2017-18
368	480	237	559	463

File Description	Document
Upload self attested letter with the list of students sanctioned scholarship	View Document
Upload any additional information	View Document
Institutional data in prescribed format	View Document
Link for additional information	View Document

5.1.2 Average percentage of students benefited by career counseling and guidance for competitive examinations as offered by the Institution during the last five years.

Response: 87.44

5.1.2.1 Number of students benefitted by guidance for competitive examinations and career counselling offered by the institution year wise during last five years

2021-22	2020-21	2019-20	2018-19	2017-18
7179	7586	5091	6532	5852

File Description	Document
Institutional data in prescribed format	View Document
Any additional information	View Document
Link for additional information	View Document

5.1.3 Following Capacity development and skills enhancement activities are organised for improving students capability 1. Soft skills 2. Language and communication skills 3. Life skills (Yoga, physical fitness, health and hygiene) 4. Awareness of trends in technology

Response: A. All of the above

File Description	Document
Institutional data in prescribed format	View Document
Any additional information	View Document
Link to Institutional website	View Document
Link for additional information	View Document

5.1.4 The institution adopts the following for redressal of student grievances including sexual harassment and ragging cases 1. Implementation of guidelines of statutory/regulatory bodies 2. Organisation wide awareness and undertakings on policies with zero tolerance 3. Mechanisms for submission of online/offline students' grievances 4. Timely redressal of the grievances through appropriate committees

Response: A. All of the above

File Description	Document
Upload any additional information	View Document
Minutes of the meetings of student redressal committee, prevention of sexual harassment committee and Anti Ragging committee	View Document
Details of student grievances including sexual harassment and ragging cases	View Document

5.2 Student Progression

5.2.1 Average percentage of students qualifying in state/national/ international level examinations during the last five years (eg: IIT-JAM/CLAT/ NET/SLET/GATE/ GMAT/CAT/GRE/ TOEFL/ Civil Services/State government examinations, etc.)

Response: 84.79

5.2.1.1 Number of students qualifying in state/ national/ international level examinations (eg: IIT/JAM/ NET/ SLET/ GATE/ GMAT/CAT/GRE/ TOEFL/ Civil Services/ State government examinations, etc.)) year-wise during last five years

2021-22	2020-21	2019-20	2018-19	2017-18
20	63	42	20	25

5.2.1.2 Number of students appearing in state/ national/ international level examinations (eg: IIT/JAM/ NET / SLET/ GATE/ GMAT/CAT,GRE/ TOEFL/ Civil Services/ State government examinations) year-wise during last five years

2021-22	2020-21	2019-20	2018-19	2017-18
25	75	50	24	27

File Description	Document
Upload supporting data for the same	View Document
Institutional data in prescribed format	View Document
Link for additional information	View Document

5.2.2 Average percentage of placement of outgoing students during the last five years

Response: 21.01

5.2.2.1 Number of outgoing students placed year - wise during the last five years.

2021-22	2020-21	2019-20	2018-19	2017-18
133	757	392	348	489

File Description	Document
Upload any additional information	View Document
Self attested list of students placed	View Document
Institutional data in prescribed format	View Document
Link for additional information	View Document

5.2.3 Percentage of student progression to higher education (previous graduating batch).**Response:** 22.94**5.2.3.1 Number of outgoing student progressing to higher education.**

Response: 747

File Description	Document
Upload supporting data for student/alumni	View Document
Institutional data in prescribed format	View Document
Link for additional information	View Document

5.3 Student Participation and Activities**5.3.1 Number of awards / medals won by students for outstanding performance in sports / cultural activities at inter-university / state / national / international events (award for a team event should be counted as one) during the last five years.****Response:** 28**5.3.1.1 Number of awards/medals won by students for outstanding performance in sports / cultural activities at inter-university / state / national / international events (award for a team event should be counted as one) year - wise during the last five years.**

2021-22	2020-21	2019-20	2018-19	2017-18
5	8	8	4	3

File Description	Document
Institutional data in prescribed format	View Document
e-copies of award letters and certificates	View Document

5.3.2 Presence of Student Council and its activities for institutional development and student welfare.**Response:**

Jamia Hamdard believes in equal opportunity to all and overall development of the university and students as well. Students Advisory Council of Jamia Hamdard is comprised of student members from different schools specifically called Student's Advisory Council. Along with university student council a very successful and active council of students is Student Nurses Association, widely Known as SNA unit of

Rufaida College of Nursing.

SNA is a nation-wide organization of nursing students at undergraduate level established in 1929 at the time of annual conference of the Trained Nurses Association of India in Madras. A wide variety of co-curricular, sports and cultural activities are encouraged at all levels for the SNA student members, keeping in view aims and objectives of the association. Jamia Hamdard believe in engaging the students in co-curricular activities to create a connection with their alma mater.

Every year SNA elections are organized and students are selected for various positions such as President, Vice President, Secretary, sports In- Charge, Mess in-charge, Entertainment and editorial in-charge. The selected students learn leadership quality and the skills to be able to work as a team and enhance individual skills as well. Jamia Hamdard strongly believes in contributing to the nation building and shaping the students to be a responsible citizen learning moral and social responsibility, and environment consciousness during their education span.

The diversity of activities is derived from the professional, social, cultural, environmental and recreational spheres to strengthen curricular and extracurricular activities of the student nurses. Affairs of Student Nurses Association are managed at the level of unit (School level), state and at national level.

Student Council organizes various activities like advocacy of profession, fund raising, socio-cultural, sports & recreational activities, organization of conferences and meetings. In addition, there are numerous co-curricular activities in the shape of article writing, poetry writing/recitation, poster competition, debates, dance, song, fancy dress and gardening etc. are encouraged. Educational tours, cultural/ literary and sports events trips are organized under the guidance of teacher SNA in-charges and core team of student council.

Student members have hosted and participated annually in various health care events at state level such as MTNL Health Mela, having an exposure at various platforms, it helps to explore hidden talents, enhance the present skills and inculcates a sense of responsibility towards society and nation in general. Student council members learn to work for social cause too, such as raising funds and annual Cancer Support walks for supporting the cause of cancer patients in collaboration with CanSupport an NGO.

Being located in the heart of country, Jamia Hamdard encourages a culture of unity in diversity where student from all over India and across the globe work as a team. Along with educational learning, co-curricular and sports activities are considered as strong pillars of overall development for students.

Jamia Hamdard expects from its students to carry forward the legacy of founder of the university, Janab Hakeem Abdul Hameed Saheb who believed in contributing towards the society, education and women empowerment.

File Description	Document
Upload any additional information	View Document
Link for additional information	View Document

5.3.3 Average number of sports and cultural events / competitions organised by the institution per

year

Response: 15.2

5.3.3.1 Number of sports and cultural events / competitions organised by the institution year - wise during the last five years.

2021-22	2020-21	2019-20	2018-19	2017-18
14	5	24	21	12

File Description	Document
Upload any additional information	View Document
Report of the event	View Document
Institutional data in prescribed format	View Document
Link for additional information	View Document

5.4 Alumni Engagement

5.4.1 The Alumni Association / Chapters (registered and functional) contributes significantly to the development of the institution through financial and other support services.

Response:

The Jamia Hamdard Alumni Association is registered as, “The Alumni Association of Jamia Hamdard” (**TAAJH**) under Societies Registration Act XXI of 1860 in Distt. South-East, Government of NCT of Delhi. The TAAJH is located at Jamia Hamdard G/F, M.B. Road, Hamdard Nagar, New Delhi-110062. The Registration Number of **TAAJH** is **S-E/1462/Distt. South East/2018**.

The mission of the alumni association is to consolidate the alumni base of Jamia Hamdard on official platform endorsed by the University. This would give the feeling of “belongingness” to the alumni and they would “feel connected” and would continue to take pride in our achievements and would do handholding where ever required. The alumni association intends to serve and support the alma mater and is expected to realize its objectives.

The aims and objectives of the alumni are given below:

- To act as a bridge between Jamia Hamdard and the industries/ organizations where the alumni (*HAMDARDIANS*) serve, for interaction on new developments in different disciplines of Health Sciences (Unani, Medical, Pharmacy and Nursing), Allied health fields (Physiotherapy/ Rehabilitation Sciences), Life Sciences, Information, Technology and Communication (IT) and Management and others.
- To provide a constructive, vivacious and vibrant ecosystem for fostering ties between the alumni

and the alma mater and as well as amongst the alumni across the schools.

- To positively contribute and enforce the university's mission and vision and help in taking the alma mater to newer heights and be recognized among the global players in the field of academic, research, innovation and outreach.
- To help the alumni to take forward their professional aspirations and offer support for entrepreneurship programs.
- To assist the Schools to promote best practices in R & D activities, testing and consultancy and organize programmes on personality development, interview technique, (GDs/PIs) and leadership development in fields of education in health science.
- To encourage the students from this university by awarding prizes to meritorious students showing bright performance in the field of academics/scholastic, co-scholastics, sports, literary and cultural spheres.
- To enrich the schools and Central Library by donating books and also by subscribing journals in the relevant fields.

Support from the Alumni:

Good number of alumni offered support to the meritorious students financially and by conducting career counselling programs during alumni interaction sessions.

For example:

- An alumni of Jamia Hamdard, Prof. Sanjay Garg (M.Pharm from SPER, Jamia Hamdard) instituted Sanjay-Alka Garg Award to be given every year to the topper of M.Pharm in Pharmaceutics (Rs.20,000/- per year) in November-December **2018**. He also provided four-month free research training in his lab in Australia for a PhD scholar in Pharmaceutics from Jamia Hamdard. Prof. Sanjay Garg is Director, Centre for Pharmaceutical Innovation and Development (CPID), Co-Director, China Australia Centre for Health Science Research (CACHSR), Adelaide, Australia.
- Seven Distinguished Alumni of Jamia Hamdard, delivered lectures on various study, research and job options after graduation in Unani School (SUMER), **2019** from 10th July 2019 - 23rd July 2019 organized by SPER, Department of Rehabilitation Sciences, Jamia Hamdard, under the aegis of **TAAJH**.

File Description	Document
Any additional information	View Document
Link for additional information	View Document

5.4.2 Alumni contribution during the last five years (INR in Lakhs)

Response: A. ? 100 Lakhs

File Description	Document
Any additional information	View Document
Link for any additional information	View Document

Criterion 6 - Governance, Leadership and Management

6.1 Institutional Vision and Leadership

6.1.1 The institution has a clearly stated vision and mission which are reflected in its academic and administrative governance.

Response:

As per the Memorandum of Association (MoA) of Jamia Hamdard the Vision and Mission are as follow:

Vision(s)

“To provide international quality higher education and undertake cutting-edge research in the fields of natural science and technology and social sciences and particularly promote study of modern and traditional, especially Unani, medicine systems encompassing a holistic and integrative approach to healthcare and to meet societal education needs of underprivileged Indian communities.”

Mission(s)

a) To promote and advance the cause of higher education through modern methods of teaching and advanced research in such branches of knowledge as the Jamia Hamdard may continue to develop core-competence for and as may be in consonance with the emerging needs of India in general and underprivileged communities.

b) To co-operate, collaborate and associate with national and international organizations and institutions in any part of the world having mission wholly or partly similar to those of the Jamia Hamdard and as per the provision of the UGC regulations in place from time to time.

c) To provide avenues for higher education leading to excellence and innovations in such branches of knowledge as may be deemed fit primarily at Under-graduate, Post-graduate, and doctoral levels, fully conforming to the concept and idea of the University.

The vision and mission of Jamia Hamdard are clearly reflected in its academic programs. For example, one of the major elements of Mission is to promote medical education and research with focus on Unani medicine system. The School of Unani Medicine and Research offers programs at undergraduate (BUMS) and post-graduate (MD- Unani) levels. Besides, for student from Madarsa background a Pre-tib program is offered which is a kind of bridge program enabling them to get prepared for BUMS. Seats have been earmarked in BUMS program for student from Pre-tib program. Moreover, Jamia Hamdard is contemplating to start Ph.D. program in the school in and interdisciplinary research domains. Healthcare education is complemented with a national Medical Commission (NMC) approved Medical School (Hamdard Institute of Medical Sciences & Research, HIMSAR). In addition, there are program on Nursing, Physiotherapy, Occupational Therapy, Paramedical Sciences, Pharmacy, Translational and Clinical Research, Molecular Medicine, Virology and Toxicology. In the School of Management and Business Studies (SMBS) the Department of Health Management offers programs on Hospital Management and Pharmaceutical Management.

There is active collaboration between research groups of Unani Medicine and Pharmacy and

Biotechnology and Biochemistry which is in synchronization with mission of the institution related to holistic and integrative approach to healthcare.

File Description	Document
Any additional information	View Document
Link for additional information	View Document

6.1.2 The effective leadership is reflected in various institutional practices such as decentralization and participative management.

Response:

The academic and administrative management of Jamia Hamdard is decentralized and participatory. At the School level there is School Board and at the Department level there is Board of Studies (BoS) which include faculty representation at all levels (i.e. Professor, Associate Professor and Assistant Professor). The tenure of these bodies is generally two years and members are rotated. In each case there are minimum two external subject experts. At the institution level statutory bodies such as Board of Management (BoM), Academic Council (AC), Finance Committee (FC), Planning & Monitoring Board (PMB), Research & Development Cell and IQAC Committee there is representation of all the categories of teachers (i.e., Professor, Associate Professor and Assistant Professor). All the Professor and Heads of the Department of Members of the Academic Council). To deliberate on matter of urgent attention, there is Standing Committee of the Academic Council which meets on regular basis once in month.

For management of research there is a Research Advisory Committee/Council (RAC) having representation of external and internal members including industry representative(s). For matters related to individual research scholar the Student Research Advisory Committee (SRAC) has representation of internal and external members and the Research Supervisor is the Convener of the meetings of the SRAC.

Deans of the School, Heads of the Departments and Project Investigator have financial autonomy to the extent as prescribed in GFR2017.

The university promotes participative management. Ideas pertaining to academic goals, organizational progression and better campus life are collected from all stakeholders to promote efficient functioning of the university. All its stakeholders such as students, staff, alumni, parent, and employers help in infusing a positive attitude that leads to increased efficiency, improved communication, enthusiasm, better performance, motivation and job satisfaction. Believing in decentralization, the Management takes policy decisions, finance, infrastructure etc. with the help of members of the various committee. BoS discusses matters related to teaching and administrative staff and decisions are taken at these levels are implemented.

Decentralization and participative management of the university is visible in all its academic and administrative spheres. Multi-layered transparent governance system is ensured through written policies, systems and procedures, distinct job descriptions and well-organized committees, and accountability is ensured through consultation, evaluation and follow ups. Overall, various institutional practices truly reflect a decentralized and participatory approach in Jamia Hamdard.

File Description	Document
Any additional information	View Document
Link for Additional Information	View Document

6.2 Strategy Development and Deployment

6.2.1 The institutional Strategic plan is effectively deployed.

Response:

The strategic plan of the institution is deliberated at the Planning and Monitoring Board (PMB). Plans of expansion and consolidation are finalized. For financial planning (business plan) concurrence of the Finance Committee is obtained. Plans approved by the Board of Management (BoM) are implemented through Schools and Departments. Jamia Hamdard has ambitious plan of expansion and outreach. It has established an off campus at Kannur (Kerala) with due approval of the Government. Recently, a skill development Centre has been established at Moradabad (UP) for vocational education with focus on Muslim minorities which is of the strategic plan of Jamia Hamdard.

Strategic plan of Jamia Hamdard focuses on current trends in technical and interdisciplinary education strata which has increased the quality of education and research. Consequently, Jamia Hamdard has secured first position in Pharmacy in NIRF continuously for the four successive years (2019-2022). Notably, it has also secured 100 positions in Management in NIRF 2022. Jamia Hamdard has also secured 1000+ ranking in both QS and Times Higher Education (THE) ranking. The strategic plan of Jamia Hamdard with alignment of its vision and mission focus on improving the international ranking as far as quality education is concern.

The salient features of the strategic plan are:

- Developing multidisciplinary research innovation ecosystem, leading to incubation at institute, project-based learning for students.
- Publishing paper in reputed journals by faculty members and encourage students to do the same.
- Promoting both faculty members and students for national/international level events both in curricular and extra-curricular activities
- Increase number of patent filing
- Sign MoU with industry for training, interaction, inviting experts for interactive sessions.
- Organize workshops/training/ conferences and FDP for faculty.
- Enriching the curriculum by introducing value added courses

- Industrial and field visits, alumni interaction
- Training of non-teaching staff
- Internships and industry based projects for students
- Submission of projects from government and non-governmental organizations like UGC, ICMR, DST, Govt. of Delhi etc., to name a few.

The Implementation of the Strategic Plan has yielded:

- Implementation of CBCS in most of the Programs offered by Schools of Jamia Hamdard.
- Updating of curricula with revision of program outcome, course outcome in accordance with the need of socio-economic society.
- Some of the departments have filed and received grants on their patents
- Many students from the socially deprived section of society were accepted with minimal fee
 - Innovative projects were developed in the institute with combined efforts of faculty members and students
- Regular interaction with alumni helped students to decide on their future course of education and profession
- Number of faculty members pursuing doctoral program, in the institute have increased
- Number of research papers publication in UGC-CARE listed journals have increased manifold

For establishing collaboration with national and international organizations and industry there is a designated committee which peruses such proposal with are aligned with the mission and vision of Jamia Hamdard.

File Description	Document
Any additional information	View Document
Strategic Plan and deployment documents on the website	View Document
Link for Additional Information	View Document

6.2.2 The functioning of the institutional bodies is effective and efficient as visible from policies, administrative setup, appointment, service rules and procedures, etc.

Response:

The governance structure of the Jamia Hamdard ensures that the eminent scientist, industrialist, leading educationists, and academicians participate in sustaining the institutional ideas, professional ethics and tradition, and maintain viability. The strategic plan of Jamia Hamdard in alignment with its vision and mission is ensured via definite organization framework, prospective planning, dynamic leadership, and decentralized administration. The vice-chancellor, being a noted academician himself, carries out academic administration and management through well-established statutory bodies. The Board of Management (BoM) is responsible for the overall functioning of Jamia Hamdard including its finance, human resource, educational and research functions, and infrastructure arrangements. It can formulate the policies and deliberates on the academic, financial, and administrative initiatives for the future, which guides the Jamia Hamdard to serve its stakeholders as per the mission and vision statements of the university. Jamia Hamdard has following statutory bodies:

Academic Council: The academic council is academic body of Jamia Hamdard and responsible for the maintenance of standards of education, teaching and training, interdepartmental coordination, research, examinations, and tests within the Jamia Hamdard. In order to settle urgent issues a standing committee is there for approval.

Finance Committee: The finance committee is entrusted with protecting and renewing the institution's resources and assisting the board fulfilling its financial responsibilities. The committee reviews and prepares budget proposal under the direction of the head of the institution for overall development of the university.

Research & Development Cell: Jamia Hamdard has a R&D cell to monitor and address matters related to research promotion and ethics. Jamia Hamdard aims to support and promote research and research activities within and outside the institution.

Internal Quality Assurance Cell: The IQAC at Jamia Hamdard was constituted on 7th December 2011. Jamia Hamdard attempts to carve out the total quality through a persistent focus on imparting quality education, through its innovative, comprehensive, and flexible education policy. Its Internal Quality Assurance Cell (IQAC) carries out activities that encompass all aspects of the Institute's functioning. IQAC has been performing the following tasks on a regular basis:

- Improvement in quality of teaching and research by regular inputs to all concerned based on feedback from its stakeholders.
- Providing inputs for best practices in administration for efficient resource utilization and better services to students and staff.
- Providing inputs for Academic and Administrative Audit and analysis of results for improvement in areas found weak.
- Annual Quality Assurance Report (AQAR), Self-Study Reports of various accreditation bodies (UGC 12b, AISHE, NAAC, NIRF, NBA)

School Board

Board of Studies: The Board of Studies (BoS) is the basic constituent of the academic system at the Department level. Its functions will include framing the content of various programs / courses, reviewing, and updating the content from time to time, introducing new programs / courses of study etc. The core objective of academic council is to maintain the standards of education, approval of syllabi, approval of new program, admission process, teaching learning and evaluation methodologies, research initiatives and

student support facilities.

File Description	Document
Any additional information	View Document
Link to Organogram of the University webpage	View Document
Link for Additional Information	View Document

6.2.3 Institution Implements e-governance covering following areas of operation

1. Administration
2. Finance and Accounts
3. Student Admission and Support
4. Examination

Response: A. All of the above

File Description	Document
Screen shots of user interfaces	View Document
ERP (Enterprise Resource Planning) Document	View Document
Details of implementation of e-governance in areas of operation, Administration etc (Data Template)	View Document
Any additional information	View Document
Link for additional information	View Document

6.3 Faculty Empowerment Strategies

6.3.1 The institution has a performance appraisal system, promotional avenues and effective welfare measures for teaching and non-teaching staff .

Response:

1. Performance appraisal system for teaching and non-teaching staff

A good performance management system works towards the improvement of the organizational performance of teams and individuals for ensuring the achievements of the overall organizational mission and vision. An effective performance management system plays a crucial role in managing the organization in an efficient manner. Jamia Hamdard has a well-executed policy for staff performance appraisal and promotion. In line with this, the Institute is following the appraisal scheme suggested by UGC Regulations 2018. Promotions

In this scheme, the performances are classified into three categories

- (i) Teaching, learning and evaluation related activities
- (ii) Co-curricular, extension and professional development related activities
- (iii) Research publications and academic contributions

All non-teaching staff are also assessed through annual confidential reports and annual performance appraisal.

1. Effective Welfare Measures through Financial Support

Jamia Hamdard has effectively implemented the welfare schemes for the teaching and non-teaching staff by providing all the government schemes, such as gratuity, pension, commutation of pension, earned leave encashment, maternity leave, paternity leave, medical facility, leave for attending national/ international conference, health fund scheme, permission to attend FDP such as orientation programs and refresher courses, short term courses, etc. for the career development and progression of the teaching as well as non-teaching staff. Besides the above, the following benefits are given to the teaching and non-teaching staff.

- To attend workshops /seminar/ conferences both at the national and international level
- Tuition fee reimbursement for children's education of the teaching and non-teaching staff
- HNF scholarship for wards of under-privileged staff
- Fee concession for wards of employee.
- Free admission form for wards of employee
- Provident fund, permission to attend Faculty Development Program, paid maternity, and paternity leave
- Interest free housing loan for domestic employees
- Staff residence both inside and outside the university premises
- Wi-Fi facility to the staff inside the university campus including residential area.
- Medical reimbursement on annual basis up to Rs.10000 is available.

(C) Cater to Emotional Needs

- Staff Grievance Redressal Cell to address the issues and grievances of the staff
- Availability of full-time professional mental health counsellors for both staff and students in Rufaida College of Nursing, availability of psychologist
- Outdoor and indoor games facility for the staff to relax and to refresh physically and mentally
- Crèche facility for wards of employee
- Provision of providing suitable venue/place for marriages of wards of employees.
- Provision of providing scholars house for guest of staff.
- Sports and gym facility for the family members of the staff.

Reference : The detailed policies are described in the Jamia Hamdard Policy Manual (also available on JH website)

Staff welfare policy

Staff Performance appraisal Policy

HR Policy -Teaching Staff

HR Policy -Non-Teaching staff

File Description	Document
Any additional information	View Document
Link for Additional Information	View Document

6.3.2 Average percentage of teachers provided with financial support to attend conferences / workshops and towards membership fee of professional bodies during the last five years.

Response: 2

6.3.2.1 Number of teachers provided with financial support to attend conferences/workshops and towards membership fee of professional bodies year wise during the last five years

2021-22	2020-21	2019-20	2018-19	2017-18
1	1	16	18	7

File Description	Document
Details of teachers provided with financial support to attend conferences, workshops etc. during the last five years (Data Template)	View Document
Link for Additional Information	View Document

Other Upload Files

1 [View Document](#)

6.3.3 Average number of professional development / administrative training Programmes organized by the institution for teaching and non-teaching staff during the last five years.

Response: 18.8

6.3.3.1 Total number of professional development /administrative training Programmes organized by the institution for teaching and non teaching staff year-wise during the last five years

2021-22	2020-21	2019-20	2018-19	2017-18
15	17	33	18	11

File Description	Document
Details of professional development / administrative training Programmes organized by the University for teaching and non teaching staff (Data Template)	View Document
Any additional information	View Document
Link for Additional Information	View Document

6.3.4 Average percentage of teachers undergoing online/ face-to-face Faculty Development Programmes (FDP) during the last five years (Professional Development Programmes, Orientation / Induction Programmes, Refresher Course, Short Term Course).

Response: 8.79

6.3.4.1 Total number of teachers attending professional development Programmes, viz., Orientation Programme, Refresher Course, Short Term Course, Faculty Development Programmes year wise during last five years

2021-22	2020-21	2019-20	2018-19	2017-18
27	21	42	70	31

File Description	Document
IQAC report summary	View Document
Details of teachers attending professional development Programmes during the last five years (Data Template)	View Document
Link for Additional Information	View Document

6.4 Financial Management and Resource Mobilization

6.4.1 Institutional strategies for mobilisation of funds and the optimal utilisation of resources

Response:

Jamia Hamdard is a substantially aided institute. It receives Government Grants from Delhi Govt. and

UGC. It also receives Research and Development funds from funding agencies such as CSIR, DBT, DST, AICTE, ICMR, ICSSR, ICPR, Hamdard National Foundation (HNF) and Non-governmental bodies for extension and development activities.

Apart from these two sources of Govt. grants, the resource mobilization is mainly through the following:

1. Fee from students
2. Interest on investments
3. Interest on corpus
4. Contribution from charitable societies
5. Contributions from Association of Alumni
6. Overhead charges from projects
7. Share of consultancy charges
8. Sponsorships and registration fee
9. Tender fee
10. Sale of student's application forms for admission
11. Sale of job application forms

Jamia Hamdard maintains a transparent and accountable financial management system. Finance section is involved in regulation of financial process, preparing budget, mobilizing resources, monitoring expenditures, maintaining accounts, internal and external audit. Jamia Hamdard is able to implement various quality enhancement activities with its ability to mobilize resources from different sources for new programs, research, extension, infrastructure, staff and student's welfare.

Utilization of Funds

Jamia Hamdard effectively utilizes the funds in the following ways

- Disbursal of staff salary
- Infrastructure augmentation such as construction and renovation of classrooms, laboratories, installation of solar panels, waste management units, plantation of trees, campus beautification, maintenance of staff residences, renovation of old buildings, setting-up of new centres etc.
- Hostel maintenance
- Library resources

- ERP and ICT improvement
- Software and equipment purchase
- Organizing Seminars/Endowments lectures, conferences, workshops, training programs
- Career development programs, faculty empowerment programs
- Seed money grants for promoting research
- Endowment scholarships to empower and encourage the under privileged wards of staff
- Management (HNF) scholarship to the socially and economically marginalized students
- Sports and cultural events such as Annual Sports Meet, Blood donation camp, activities of different clubs such as Literary club, Cultural club etc.
- Observing the days of national significance
- Organizing extension activities such as free health campus, blood donation camp, NSS and NCC activities.
- Managing dispensary to the inmates and the rural people
- Organizing health camps
- Welfare activities measures to teaching and non-teaching staff
- Development of green club
- Relief measures during the period of disaster like covid-19 including free vaccination to staff and neighborhood populations.
 - Providing incentive to students and teachers for their accomplishment in the field research (publication, citations).
 - Supporting research activities.

Reference: **The detailed policies are described in the Jamia Hamdard Policy Manual (also available on JH website)**

Infrastructure Utilization and Maintenance Policy

Finance Policy

File Description	Document
Any additional information	View Document
Link for Additional Information	View Document

6.4.2 Funds / Grants received from government bodies during the last five years for development and maintenance of infrastructure (not covered under Criteria III and V) (INR in Lakhs).

Response: 4082

6.4.2.1 Total Funds / Grants received from government bodies for development and maintenance of infrastructure (not covered under Criteria III and V) year wise during the last five years (INR in Lakhs).

2021-22	2020-21	2019-20	2018-19	2017-18
810.00	800.00	800.00	800.00	872.00

File Description	Document
Details of Funds / Grants received from government bodies during the last five years (Data Template)	View Document
Any additional information	View Document
Annual statements of accounts	View Document
Link for Additional Information	View Document

6.4.3 Funds / Grants received from non-government bodies, individuals, philanthropists during the last five years (not covered in Criterion III and V) (INR in Lakhs)

Response: 9887.9

6.4.3.1 Total Grants received from non-government bodies, individuals, Philanthropers year wise during the last five years (INR in Lakhs)

2021-22	2020-21	2019-20	2018-19	2017-18
809.04	1045.05	1077.39	5322.42	1634.00

File Description	Document
Institutional data in prescribed format	View Document
Annual statements of accounts	View Document
Link for Additional Information	View Document

6.4.4 Institution conducts internal and external financial audits regularly

Response:

The University has an Audit Section functioning under the Finance Officer. All financial activities of the university are audited by this section. Any departmental activity involving considerable financial overlay is scrutinized by the Audit section and sanction is accorded only after passing through the Audit. The Chartered accountants conduct regular internal and external financial audit in the university. The statutory audit covering all financial and accounting activities of the university follow the standard procedure laid by the government agencies. The mechanisms used to monitor effective and efficient use of financial resources are as follows:

- All receipts from fee, donations, grants, contributions, interest earned and returns on investments.
- All payments to staff, vendors, contractors, students, and other service providers.
- All recurring expenses such as salary, electricity, internet charges, maintenance cost, stationery, other consumable charges etc., and non-recurring expenses like lab equipment purchases, furniture, and other development expenses.

The expenses are be monitored by the accounts department as per the budget allocated by the Board of Management. The depreciation costs of various things purchased in the preceding years are also worked out. All observations/objections of CA are communicated through their report. These objections are examined by separate committees of the institute consisting of Registrar, Finance Officer Assistant Registrar (Accounts), Internal Auditor, concerned Head of the Department and any other member nominated by the Vice Chancellor/Registrar. Draft report is submitted to Finance officer for finalizing compliance report of the university. CA's audit for the previous five years has been completed and replies have been submitted to their satisfaction. It is pointed out that no objection/irregularity is outstanding. No Draft Para has ever been issued against the university by CA. All Utilization Certificates to various grant giving agencies are also countersigned by the CA. All Financial Statements for previous five years have been certified by the CA.

Work of Internal Audit of the Institute has been entrusted to the Internal Auditor of the institute. This is mainly pre-audit of major receipts and payments (above Rs. 50 thousand each) and concurrent/post audit of all other receipts and payments. He also pre-checks salary fixations, pension and gratuity payments and final payments of GPF/CPF

Reference - Finance Policy

File Description	Document
Any additional information	View Document
Link for Additional Information	View Document

6.5 Internal Quality Assurance System

6.5.1 Internal Quality Assurance Cell (IQAC) has contributed significantly for institutionalizing the quality assurance strategies and processes by constantly reviewing the teaching learning process, structures & methodologies of operations and learning outcomes at periodic intervals.

Response:

Jamia Hamdard attempts to work towards total quality through a persistent focus on imparting quality education, through its innovative, comprehensive, and flexible quality education policy. Its Internal Quality Assurance Cell (IQAC) carries out activities that encompass all aspects of the institute's functioning.

The IQAC at Jamia Hamdard was constituted on 7th December, 2011. Since then, it has been performing the following tasks on a regular basis:

- Improvement in quality of teaching and research by regular inputs to all concerned based on feedback from its stakeholders.
- Providing inputs for best practices in administration for efficient resource utilization and better services to students and staff.
- Providing inputs for academic and administrative audit and analysis of results for improvement in areas found weak.
- Annual Quality Assurance Report (AQAR), Self-Study Reports of various accreditation bodies (UGC 12b, AISHE, NAAC, NIRF, NBA)

The two examples of practices institutionalized because of IQAC initiatives are as follows:

1. Online Student Feedback System

2. Academic and Administrative Assessment and Audit

1. Feedback System

IQAC has developed an online proforma for student, alumni, employers, parents and staff feedback to gather information from all its stakeholders about the courses of their study, their objectives, relevance, availability of learning resources, teaching methodology, placement and future perspectives and so on. This online feedback system has been introduced and implemented as a quality initiative and a way to make feedback system more effective and efficient, as it involves all the students at the University to assess and improve the curriculum of the programs of study, and quality of teaching and learning in the University.

2. Academic and Administrative Assessment and Audit

The process of Academic and Administrative Audit intends to monitor and enhance the quality of education and administrative processes through proper guidelines for both teaching faculty, students, and university administrators so as to ensure qualified students and researchers passing out from Jamia Hamdard and quality and efficiency in administrative processes.

The main objectives of AAA have been envisaged as follows.

1. To understand the existing system and assess the strengths and weaknesses of the departments and administrative units and to suggest the methods for improvement and for overcoming the weaknesses.
2. To assess the academic and research performance of the individual faculty in a department.
3. To assess the academic and research performance of the school/department as a whole and its readiness for accreditation, rankings and other such exercises undertaken at national and international levels.
4. To identify strengths and weaknesses of the department.
5. To assess the performance of the department in terms of enabling the learning environment for students.
6. To assess the status of the department in terms of availability of facilities and amenities to meet the on-campus requirements of faculty and students.
7. To make individual departments and administrative units accountable.

File Description	Document
Any additional information	View Document
Link for Additional Information	View Document

6.5.2 Institution has adopted the following for Quality assurance 1. Academic Administrative Audit (AAA) and follow up action taken 2.Confernces, Seminars, Workshops on quality conducted 3. Collaborative quality initiatives with other institution(s) 4.Orientation programme on quality issues for teachers and students 5. Participation in NIRF 6.Any other quality audit recognized by state, national or international agencies (ISO Certification, NBA).

Response: A. Any 5 or more of the above

File Description	Document
Upload e-copies of the accreditations and certifications	View Document
Upload details of Quality assurance initiatives of the institution (Data Template)	View Document
Any additional information	View Document
Paste web link of Annual reports of University	View Document
Link for Additional Information	View Document

6.5.3 Incremental improvements made for the preceding five years with regard to quality (in case of first cycle), Post accreditation quality initiatives (second and subsequent cycles).

Response:

Jamia Hamdard strive hard for the benefits of all its stakeholders through quality education.

IQAC of Jamia Hamdard emphasizes on imparting quality education, through its innovative, comprehensive, and flexible quality policy. Its carries out activities that encompass all aspects of the university functioning. Jamia Hamdard has participated in NIRF Ranking and bagged first rank in Pharmacy for consecutive four years. Jamia Hamdard has also participated in Times Higher Education ranking and QS Ranking.

Moreover, IQAC has conducted workshops and organized seminars, special lectures on quality related issues including implementation of CBCS, introduction of Program outcome and Course outcome in all its program, implementation of NEP2020 etc. Some of the program details are given as:

- Orientation program on “MOOCs and Blended Learning” [for faculty members of Jamia Hamdard] (December 01, 2021).
- Orientation program on "Outcome Based Education (OBE) and Curriculum Design" (February 02, 2022).
- Orientation program on "Predatory Journals and UGC-CARE Listing of Journals (February 03, 2022)
- Faculty Development Program (FDP) on “Whole Brain Classroom and Modern Dynamics and Pedagogy” (May 08, 2028)
- Faculty Development Program (FD) on Productivity Quotient (March 25, 2019)
- Seminar on Research Ecosystem in HEIs and its impact on Accreditation and Ranking in Collaboration with NAAC and SPONSORED BY DST-Purse on August 1, 2022
- Special Lecture on NEP2020: Concept, Relevance and Implementation. June 14, 2022
- Faculty Development Program on “Advancement In Medical And Interdisciplinary Sciences: Adaptation For Effective Teaching & Learning Techniques” (17.9.2019-23.9.2019)
- Faculty Development Program on Entrepreneurship March 10- 24, 2021
- Manual for Academic and Administrative Audit (AAA) prepared and adopted.
- Audit Committees constituted. Academic audit of all Nine Schools completed.

Some of the major activities of Jamia Hamdard in preceding years are as follows-

- Complete adoption of Choice Based Credit System
- Establishment of National Cadet Corps (NCC) Girls Sub-Unit
- Establishment of Research & Development Cell
- ICT Initiatives
- Centre for Scientific and International Collaborations
- Implementations of Academic Bank Credits
- Establishment of Environmental quality Cell (EQC)
- Establishment of Center for Teaching Support and Innovation (CTSI)
- Establishment of Center for Career Counselling and Guidance Cell
- Establishment of Eco Club
- Establishment of Cultural Club
- Establishment of Industry-Academia partnership Cell
- Appointment of Adjunct Professor/Adjunct Faculty
- Constitution of Jamia Hamdard Alumni Affairs Committee
- Constitution of Rose Society
- Constitution of Electoral Literacy Club

File Description	Document
Any additional information	View Document
Link for Additional Information	View Document

Criterion 7 - Institutional Values and Best Practices

7.1 Institutional Values and Social Responsibilities

7.1.1 Measures initiated by the Institution for the promotion of gender equity during the last five years.

Response:

Jamia Hamdard provides a safe environment for all and is proactive in fostering gender sensitivity and equality. To ensure that the education system supports gender-equitable and neutrality, the main objective is to ensure that our students have the personality, exposure, skills, and self-confidence, to be trained for their professional careers, and to realize their full potential as individuals and fostering gender sensitivity and equality.

Specific facilities provided for women in terms of:

- Safety and security
- The security on campus is under direct purview of the Chief Proctor's office who is assisted by a team of female deputy and assistant Proctors and other support staff and security guards.
- The campus is under CCTV surveillance and the security is provided 24x7 throughout to maintain discipline and to ensure safety on campus.
- The entry and exit at all gates is strictly regulated.
- Female security personal are deputed at all girls' hostels and appropriately placed at various locations within the campus round the clock.
- Girls' common rooms with attached washrooms and first aid room available in all schools of the institution.
- Suggestion and complaint box is provided. Female students can give suggestions or file complaints against unfair practices, harassment. These are situated in every academic block to encourage students to raise their voice against any discrimination.
- Gymnasium and playground: time slot fixed for females only.
- Women's saloon
- General store and stationary shop: in-campus facility.
- Girl's hostel facilities:
 - Adequate safety and security in the hostel through security guards, female attendants and wardens.
 - Regular attendance is maintained and night out is allowed only with prior permission.
 - Regular maintenance, repairs, medical facilities and ambulance for emergency purposes is available round the clock.

1. Internal Complaint Committee (ICC) is in place to address grievances and issues of sexual harassment, if any. Several initiatives have been taken and implemented to prevent harassment. Prompt actions are taken if any such incident is reported. The University takes care of special needs of girl students, thereby ensuring a safe and friendly environment within the University.

- Women's Grievances Redressal Cell is to promote gender equality, women empowerment, safeguarding and promoting the well-being of all women employees and female students of the institution.

- Women Empowerment
- Women Development Cell/ club
- Equal opportunity cell
- NCC Women Wing, Jamia Hamdard

2. Counselling:

- Career counseling
- Mentoring
- DSW (Female wing)

3. Day Care Center

A daycare facility is equipped with child-sized furniture and bathroom fixtures, cctv camera, provides toys, games, books, audio-visual aids like cartoon movies, animated movies etc. and a spacious outdoor playing area. The facility has well-trained staff for attending to the needs of the kids.

- Every year various programs on gender sensitization are planned such as workshops / seminars on:

1. Gender equity / attitude/ awareness
2. Prevention of sexual harassment
3. Women empowerment
4. Women health and hygiene
5. Women's day and many other relevant topics.

File Description	Document
Specific facilities provided for women in terms of: a.Safety and security b. Counselling c. Common Rooms d. Day care center for young children e. Any other relevant information	View Document
Annual gender sensitization action plan	View Document

7.1.2 The Institution has facilities for alternate sources of energy and energy conservation measures

- 1.Solar energy
- 2.Biogas plant
3. Wheeling to the Grid

4.Sensor-based energy conservation**5. Use of LED bulbs/ power efficient equipment**

Response: A. 4 or All of the above

File Description	Document
Geotagged Photographs	View Document
Any other relevant information	View Document

7.1.3 Describe the facilities in the Institution for the management of the following types of degradable and non-degradable waste (within 500 words)

- **Solid waste management**
- **Liquid waste management**
- **Biomedical waste management**
- **E-waste management**
- **Waste recycling system**
- **Hazardous chemicals and radioactive waste management**

Response:

- **Solid waste management**
- **Liquid waste management**
- **Biomedical waste management**
- **E-waste management**
- **Waste recycling system**
- **Hazardous chemicals and radioactive waste management**

1. Solid waste management

Jamia Hamdard has signed a Memorandum of Understanding with the Indian Pollution Control Association (IPCA) for implementation of the project of segregation of organic waste, its recycling and treatment (Project S.O.R.T). The project is conceptualized to maximize the utilization of resources to reduce waste, which would indirectly result in less air, water, and soil pollution, reduced pressure on landfill sites and reduce cost on transportation. Under this project, high technologically driven patented composters (designed and procured from Australia) will be installed in the campus which will convert the wet waste produced in the campus into organic manure. The workshops will be conducted by IPCA to create awareness among students, teachers, waste collectors, housekeeping staff on the methods and technologies for successful handling and management of solid waste.

2. General and domestic liquid wastes

General and liquid wastes of the university are treated by Effluent Treatment Plant/Sewage Treatment Plant (ETP/STP) plants and recycled back to irrigate lawns, Herbal Garden and experimental fields. To minimize the use of fresh water in irrigation of lawns, gardens, parks and also to fulfill the mandatory requirement of working hospitals, ETP/STP plants have been installed at two locations in campus i.e., near

old block of Hakeem Abdul Hameed Centenary Hospital (HAHCH) and new Hospital building. The capacity of the plants is 250 KLD and 400 KLD, respectively. Treated water from both plants is being used for irrigation purposes at different locations in the campus with zero discharge to the municipal drain. The pipeline and pumping accessories have been installed to facilitate the process of irrigation. Lawns and herbal gardens of the Jamia Hamdard campus are irrigated with the treated water. Besides, some smaller units are also installed for using treated water for irrigation at different locations like, Scholars' House and International Hostel.

3. Biomedical and hazardous waste management

House-keeping staff is aware of hazardous wastes and non-hazardous wastes. Hence, they use personal protective equipment's (PPE) while handling these wastes. On an average HAHC hospital generates 4500 Kg of biomedical wastes in a month, while around 25 kg biomedical wastes are generated in Animal House. Biomedical wastes are segregated at the site of production in colour coded bags/containers and stored in separate rooms meant for the purpose. Site of the storage of biomedical wastes is away from the reach of common public. Biomedical waste is then transported by Biotic waste solutions Pvt. Ltd in closed leak proof containers for further management. Walls and floors of these rooms are fixed with ceramic tiles.

4. E-waste management

- It is collected and auctioned periodically by the Department of Computer Science to the authorized dealers for further recycling. The University also contemplating to recycle e-waste internally.
- **5. Waste recycling system (2017-2022)**
- Both the solid waste and liquid waste are recycled and used in the campus in different ways. SOPs related to management of various kinds of wastes are available in the university campus.



File Description	Document
Relevant documents like agreements/MoUs with Government and other approved agencies	View Document
Geotagged photographs of the facilities	View Document
Any other relevant information	View Document

7.1.4 Water conservation facilities available in the Institution:

1. Rain water harvesting
2. Borewell /Open well recharge
3. Construction of tanks and bunds
4. Waste water recycling
5. Maintenance of water bodies and distribution system in the campus

Response: A. Any 4 or all of the above

File Description	Document
Geotagged photographs / videos of the facilities	View Document
Any other relevant information	View Document

7.1.5 Green campus initiatives include:

1. Restricted entry of automobiles
2. Use of Bicycles/ Battery powered vehicles
3. Pedestrian Friendly pathways
4. Ban on use of Plastic
5. Landscaping with trees and plants

Response: A. Any 4 or All of the above

File Description	Document
Various policy documents / decisions circulated for implementation	View Document
Geotagged photos / videos of the facilities	View Document
Any other relevant documents	View Document

7.1.6 Quality audits on environment and energy are regularly undertaken by the Institution and any awards received for such green campus initiatives:

1. Green audit
2. Energy audit

- 3.Environment audit
- 4.Clean and green campus recognitions / awards
- 5.Beyond the campus environmental promotion activities

Response: A. Any 4 or all of the above

File Description	Document
Reports on environment and energy audits submitted by the auditing agency	View Document
Certification by the auditing agency	View Document
Certificates of the awards received	View Document
Any other relevant information	View Document

7.1.7 The Institution has disabled-friendly, barrier free environment

- 1.Built environment with ramps/lifts for easy access to classrooms.
- 2.Divyangjan friendly washrooms
- 3.Signage including tactile path, lights, display boards and signposts
- 4.Assistive technology and facilities for Divyangjan accessible website, screen-reading software, mechanized equipment
- 5.Provision for enquiry and information : Human assistance, reader, scribe, soft copies of reading material, screen reading

Response: A. Any 4 or all of the above

File Description	Document
Policy documents and information brochures on the support to be provided	View Document
Geotagged photographs / videos of the facilities	View Document
Details of the Software procured for providing the assistance	View Document
Any other relevant information	View Document

7.1.8 Describe the Institutional efforts/initiatives in providing an inclusive environment i.e., tolerance and harmony towards cultural, regional, linguistic, communal socioeconomic and other diversities (within 500 words).

Response:

The institution believes in equality of all cultures, religions and people from different socioeconomic backgrounds. To provide an inclusive environment, several initiatives such as organizing cultural and literary programmes, celebrating commemorative days, and inviting distinguished personalities to share

knowledge and experiences on various social, religious, cultural and scientific aspects are regularly carried out.

The university aims to inculcate and promote pride for Indian cultural heritage amongst students and youth who are the future of the society. The SPIC-MACAY-JH chapter regularly organizes cultural events in the university to promote Indian music and culture, and has received excellent participation from teachers and students at the various events organized. The events organized encourage the students to learn and practice Indian music and culture.

The university invites distinguished personalities as speakers from a variety of expert domains with a purpose to create awareness and spread knowledge on various social, religious, cultural and scientific aspects and to provide an inclusive environment to all.

All the Indian festivals are celebrated with great fervour and enthusiasm on campus by the university, to infuse a sense of “Unity in Diversity” among the students and staff of the university. The university also aims to create awareness and spread knowledge on excellence in various fields such as medicine, chemistry, physics, economic sciences and peace and therefore, organized the Nobel Prize symposium with lectures delivered by distinguished personalities of repute, to share with the audience, the main drivers that led the recipients’ to the nobel prize.

The university in collaboration with Jashn-e-Adab aims to celebrate art, culture and literature in Hindi and Urdu across India, through literary activities, and make a conscious effort to create an informal platform to promote peace and harmony in society through art and literature.

The institution also organizes a cultural festival every year, which is an annual fest of literary, creative and performing activities participated by thousands of students from all the schools of the university with enthusiasm and fervour. Many cultural activities by students, Youth Mushaira, Mai Bhi Tere Jaisa Hun (Performance by teachers of Jamia Hamdard), Rang-e-Ghazal, and inter-university Bait Bazi programmes are organized. Jamia Hamdard hosts about 300-400 international students from more than 30 countries across the globe, providing a true cross cultural environment. A cultural evening “Rendezvous” is organized for foreign students studying in Jamia Hamdard.

File Description	Document
Supporting documents on the information provided (as reflected in the administrative and academic activities of the Institution)	View Document
Any other relevant information	View Document

7.1.9 Sensitization of students and employees of the Institution to the constitutional obligations: values, rights, duties and responsibilities of citizens (within 500 words).

Response:

In recognition of Article 51A of the constitution which urges promotion of respect for ideals and

institutions of the constitution, Jamia Hamdard has been attempting to inculcate the spirit of the constitution in the minds of its students and employees through its educational philosophy and activities.

Activities have been organised to celebrate the constitution day. For instance, NSS Jamia Hamdard organized a programme on 26th November to celebrate Constitution Day.

School of Humanities and Social Sciences, School of Law and School of Engineering Sciences and Technology are offering as many as fifteen courses on constitution and issues pertaining to constitution. Several lectures have been organized at the University level on constitutional issues to disseminate the true spirit of the Constitution. On July 16, 2018 Justice (Retired) Iqbal Ahmed Ansari, Chairperson, Punjab State Human Rights Commission delivered a distinguished lecture on 'Indian Judiciary: An Arbiter of Conflicting Interests', where he emphatically talked about the role of judiciary. On December 6, 2018 Prof (Dr.) Manoj Kumar Jha, Member of Parliament, Rajya Sabha delivered a distinguished Lecture on 'Hindustan Ki Awaaz: Voice of India' explaining how the survival democracy is intertwined with preservation of the constitution. Salman Khurshid, former cabinet minister delivered another distinguished lecture on 'Constitutional Morality' on November 11, 2019. He eloquently spoke about the philosophy embodied in the constitution.

Jamia Hamdard has also been making efforts to implement constitutional directions within its limited capacity. For instance, School of Law has taken an initiative to fulfil the mandate of Article 39A which calls for providing free legal aid to the poor and needy. A Legal Services Clinic has been established in collaboration with Delhi Legal Aid Services Authority (South), where practicing lawyers visit to provide free legal assistance. Several legal awareness camps and social outreach events in the neighbouring areas have been organized on issues such as domestic violence, Motor Vehicles Act, consumer awareness etc. to make people aware about legal and constitutional remedies. A workshop on Right to Information Act was also organized on November 19, 2019 to create awareness about right to information. Two former Central Information Commissioners, Prof. Sridhar Acharya and Prof. M. M Ansari graced this occasion and spoke about ways to meaningfully exercise the right to information. Similarly, a session on 'significance of Article 39A: Equal Justice and Free Legal Aid' was held on December 16, 2021.

School of Law also organized several lectures on constitutional issues such as 'Why Constitution Matters' by advocate Karuna Nundy on November 27, 2021, 'Indian Constitution and Minority Rights' by Abdul Matin, Assistant Professor, Jadavpur University, Kolkata on December 2, 2021, 'Dr. B.R Ambedkar's Contribution to Indian Constitution' by Professor Narender Kumar, Chairperson, Centre for Political Studies, Jawaharlal Nehru University (JNU), New Delhi on March 7, 2022 and 'Elements of Constitutionalism in Indian Constitution' by Dr. P. Puneeth, Associate Professor, JNU on March 15, 2022.

7.1.10 The Institution has a prescribed code of conduct for students, teachers, administrators and other staff and conducts periodic programmes in this regard.

- 1. The Code of Conduct is displayed on the website**
- 2. There is a committee to monitor adherence to the Code of Conduct**
- 3. Institution organizes professional ethics programmes for students, teachers, administrators and other staff**
- 4. Annual awareness programmes on Code of Conduct are organized**

Response: A. All of the above

File Description	Document
Details of the monitoring committee composition and minutes of the committee meeting, number of programmes organized, reports on the various programs etc., in support of the claims	View Document
Code of ethics policy document	View Document
Any other relevant information	View Document

7.1.11 Institution celebrates / organizes national and international commemorative days, events and festivals (within 500 words).

Response:

The institution organizes various events and activities to celebrate commemorative days and festivals. To inculcate a sense of patriotism amongst the students, all events end with National Anthem. Plantation drives are organized invariably on various occasions to support the green campus initiative.

Besides celebrating the days of National importance like Republic Day, Independence Day and Gandhi Jayanti, the university also organizes events and activities on various other occasions like Founders Day, World Health Day, World Food Day, Constitution Day, Martyr's Day, World Oral Health Day, World Optometry Day, World Wildlife Day etc. The faculty, students and non-teaching staff actively participates in these events like speech, nukkad natak, singing and poem recitation on these occasions. The university also celebrates various Indian festivals to promote National integration. Special programs are organized regularly, where the students and staff join in the festivities and learn about each other's religion, culture and participate in the activities and events.

The university also celebrates National Science Day on 28th February, 2022 to encourage scientific research amongst the faculty and students. On this day it also felicitates the contributions of its faculty and students are celebrated and award them with cash prizes for outstanding contributions in their areas. To further promote research and learning various distinguished and guest lectures are also regularly organized at the university.

Unani Day is celebrated at the University with an aim to create awareness about the Indian traditional medicines. University also celebrated 60th National Pharmacy Week to create awareness about various aspects of medication.

To promote environmental best practices among the students and faculty, various events are organized on days like World Environment Day, National Pollution Control Day, World Earth Day, World Water Day, International Ozone Day, International Day of Forests etc, to create awareness about the importance of environment safety and conservation. Activities like plantation drives are also organized. National Energy Conservation Day is celebrated to promote energy conservation in campus and reduce the energy usage.

University also celebrates art and culture by organizing various cultural and literary events. On special occasions like Teachers Day the students organize various activities to express their gratitude towards the

teachers and offer their respect to Dr. Sarvepalli Radhakrishnan. The university celebrates the efforts of women in the society by organizing various events on Women's Day. Women who have shown outstanding contributions in their fields are invited as special guests on the occasion to share their wisdom with the faculty and students and encourage them to succeed in life.

The university promotes healthy mind and body by celebrating Yoga Day every year. Events are organized where Staff and students participate and perform various yoga asanas. Trainers are invited to teach various asanas to the students and staff. Apart from these activities the institute also actively participate in all government schemes like Swatch Bharat Abhiyaan, Jal Shakti Abhiyaan, Aazadi ka Amrit Mahotsav etc. Various events, rallies and awareness drives are conducted from time to time as part of these activities.

File Description	Document
Geotagged photographs of some of the events	View Document
Any other relevant information	View Document
Annual report of the celebrations and commemorative events for the last five years	View Document

7.2 Best Practices

7.2.1 Describe two best practices successfully implemented by the Institution as per NAAC format provided in the Manual.

Response:

BEST PRACTICE - 1

1. Title of the Practice:

Social and Community Outreach initiatives undertaken, as institutional social responsibility.

2. Objectives of the Practice:

- To collaborate with external group(s)/ individuals/ organizations to enhance the learning experience socially.
- To enhance their societal, and moral, capabilities as well as responsibilities to become better individuals.
- To provide students with support, and guidance, so that it can contribute to holistic student success and the achievement of desired attributes.
- To establish holistic care for the patients admitted to the COVID ward during the pandemic times.
- Maintaining the sound physical as well as mental health of the staff working for COVID-19 patients.
- To provide financial aid to students who lost their parents or those affected by COVID and help them continue with their studies.
- To raise awareness among the community about prevention and preservation of health and the

environment.

- To improve the health of people that is totally dependent on hygiene education and sanitation practices that will help them to get a better education with a healthy mind.
- To initiate and work for the upliftment of sex workers, girls, street kids, and trans genders by creating awareness, helping them gain education, rehabilitating them or enabling/educating them to develop skills that would help them earn a respectable livelihood.

3. The Context:

Jamia Hamdard has always been committed to the cause of humanity and society and continues to strive for the upliftment of the needy and the poor in the community. Several activities have been organized related to social and community outreach and service. These activities develop a sensitization among students, faculty and staff.

4. The Practice:

a. Health Camps

Several health camps were organized for community outreach services in adjoining areas of the university. Most of these camps were organized by various departments of SUMER (School of Unani medicine Educational research) and Rufaida College of Nursing. There were free camps catering to the needs and health issues of different age groups and are related to maternal and child health, and other health camps have been organized at various places in New Delhi. Free distribution of medicines was also initiated in many camps.

b. Catering to the needs of acceptance, awareness, and education to girls, street kids, sex workers, and transgenders

School of Management & Business Studies, has in the past five years organized several activities related to above aspect. Some are listed below:

- Informal School project for Street kids and also Mother and Child Health Programme (MCH) in Partnership with DMCI (Distress Management Collectives India). Informal education to the street kids of Nizamuddin, Nehru Place, Leprosy Colony, Lajpat Nagar, Mayur Vihar, and Sector 48 Noida, who do not get the opportunity to become a part of the formal education system was involved and reached out. Camps to generate awareness regarding mother and child health issues in the slum areas of Nehru Place and Nizamuddin were organized and education material for about 500 kids was distributed.
- Sanitary napkins' project of DMCI focused on menstrual hygiene among adolescent girls and women in streets and slums and on implementation of Menstrual Hygiene Programme in which 4,600 sanitary napkins were distributed
- Mid-Day meal project for street kids and Ration distribution organized by Distress Management Collectives India in collaboration with Jamia Hamdard. As part of the project, 15000 mid-day meals were provided.
- Rehabilitation project for sex workers at GB Road Katkadha organized by DMCI in collaboration with Jamia Hamdard. The project focused on a rehabilitation project for the sex workers to create alternative income generation and livelihood opportunities viz., mask making and decorative items and their sale.

- Department of Healthcare & Pharmaceutical Management, SMBS, has been working on Transgender healthcare in partnership with Association of Transgender Health of India (ATHI) and Two Transgender conferences IPATHCON 2019 & IPATHCON 2020 with theme on “Demystifying Transgender Healthcare: Addressing the felt need” on 1st – 2nd November 2019, and 2020 were held

c. Unnat Bharat Abhiyan

Jamia Hamdard in collaboration with NGOs like “Reaching Sky Foundation: A Delhi Based NGO”, the Business and Employment Bureau (BEB). And others of the kind like Prajna Foundation and Sewa Bharti, performed several social activities. Five Villages namely, Chattarpur, Kalkaji, Deoli, Said ul Ajab, and Mehrauli were adopted under this banner. Several activities performed under outreach were: call for volunteers, orientation sessions, visits to the villages, household surveys, and need analysis. Two projects under UBA were also approved (2019, 2020) worth Rs. 1L each.

As part of the project, the team installed Portable Outdoor Wash Station (POWS), developed a health and sanitation app, and for the betterment of the villagers performed sanitation training, and drive was also organized. People were taught personal hygiene and sanitation through interactive activities by JH-WSHE app. Ten Foot Sanitizer Dispenser (Size 14*36 inch) with vinyl printing, Lamination, MDF Mounting, and fitted in the iron stand were installed in Sudhar Camp region Kalkaji and previously a thorough interaction with the villagers and related foundations in the village was performed.

d. COVID-19 related practices

Activities undertaken during Covid -19 pandemic

1. Awareness and Prevention for Preparedness Response Training on COVID-19

Provided COVID-19 expertise through online lectures and seminars, training of trainers for and providing financial help to the students orphaned due to COVID was introduced. A special fund “Vice Chancellor’s Fund for Benevolence” was created by collecting one day salary of the staff to provide financial support to students who were affected by COVID-19 pandemic or their families affected by COVID-19 pandemic.

e. To sensitize the students about the societal responsibilities

Various student chapters/cells/councils conducted activities and events to sensitize the students about the roles and responsibilities they should undertake which would help them to become better individuals. All the outreach activities had huge number of students as volunteers, and active participation was seen. Under these, donations in the form of toys/old clothes, etc. were collected and given to the needy/poor. IEEE Jamia Hamdard student branch performed one such collection initiative on 1st October, 2019.

5. Evidence of Success

- The team installed Portable Outdoor Wash Station (POWS), developed a hygiene and sanitation app and for the betterment of the villagers performed sanitation training and drive. People were taught personal hygiene and sanitation through interactive activities by the JH-WSHE app.
- Large participation of the needy in health camps speaks volumes about the awareness that was created

- The setting up of COVID center/quarantine center was well appreciated by the government and was a helping hand to their efforts in handling COVID-affected people.
- The conferences organized for transgender had several deliberations and as an outcome it is expected that some collaborations with government agencies/NGOs would be initiated for the empowerment of the transgenders.

6. Problems Encountered and Resources Required:

- The major problems encountered were providing follow-up care and referring the patients to tertiary care for further evaluation.
- Procurement of resources required to upgrade as per the patient's needs.
- Convincing the street kids, and villagers to adopt the hygiene aspect in day-to-day life

7. Note (OPTIONAL)

8. Coordinators/In-charges who have been assigned to the above Best Practice

a). NSS Coordinators

b). Dean Students Welfare

BEST PRACTICE - 2

1. Title of the Practice:

Nature conservation through participation of students and teachers.

2. Objectives of the Practice:

- To motivate students to keep their surroundings green and clean by undertaking plantation drive.
- To promote ethos of conservation of nature by involvements in care and upkeep of plants.
- To motivate Eco-Club members to imbibe habits and life style more close to nature.
- To sensitize the Eco-Club members to practice and learn how to nurture plants especially indoor plants so that the same may be practiced at home also.
- To contribute to plantation drive on World Environment Day

Goal: Rufaida College of Nursing is an Eco-Club member which works under objectives of environment related activities such as awareness drives, nukkad natak, seminars and plantation drive from time to time. One of the practices followed regularly and on daily basis is upkeep of the plants of Eco-Club at Rufaida College of Nursing.

3. The Context:

The high rise in air pollution due to the smog, chlorofluorocarbons, burning of leaves and trash is an alarming and emergency situation, putting life and health of people at risk. Most importantly small children and geriatric population is vulnerable. Small practices at home and college does bring a big impact.

4. The Practice:

Rufaida College of Nursing, Jamia Hamdard is a member of Eco Club under Department of Environment, Govt. of NCT of Delhi since 2012. The environmental Department has always emphasized on plantation drives keeping in view the rise of air pollution and climate change. We celebrate World Environment Day every year and nurture ozonizer plants, indoor and outdoor plants, and climbers at our college premises since last few years. As a specific objective, the active involvement of Eco-Club faculty members and the students are involved in upkeep of plants, they water the plants and care for the plants. They have adopted the plants and they do every activity related to it such as watering, putting fertilizers and cleaning of the area from time to time.

The practice provides an attachment to nature and benefits the students in a way that they learn that plants can be kept at home. Many have started to keep plants such as Tulsi, Snake plant, money plant and Areca palm at home also. The uniqueness about the activity is that the youth of this generation is more involved in digital media and detached from nature so close to them. It is very important to inculcate the practice and habits related to preservation and protection of environment. Debates, poster and poetry recitation competitions and 'best out of waste' events are held regularly in college and at university level. Every year awareness drives like 'khelo Holi Naturally' during Holi and 'Say NO to Firecrackers' during Diwali are organized.

5. Evidence of Success:

From time to time during the past rainy season, plantation drive has been practiced at Rufaida College of Nursing. Now we have as many as 80 plants. 50 plants were received from the free nursery under Govt. of NCT of Delhi and rest 30 were purchased. At times due to, high temperature in the months of May to August some plants could not survive. However, 60 indoor and outdoor plants have survived. Few faculty members who were given plants from Eco-Club have maintained the same at home for many years.

6. Problems encountered and Resources Required:

Manpower, time to time management of plants with fertilizers and continuous water supply is required for upkeep of the plants. Plants require special care during peak of summer season. The plants are shifted from open area to shade so that indoor plants may survive in heat. In the month of summer, when the students are on vacation, faculty members, nonteaching staff takes up the responsibility and they water the plants. When rainy season is delayed, the plants are watered twice a day on Fridays so that they may survive the two days off in college i.e., on Saturdays and Sundays. A gardener is called to check the plants and their growth.

7. Note (OPTIONAL):

8. Coordinator/In charge who has been assigned for the Best Practice:

- a) Ms. Veena Sharma / Ms. Nahid Zebi
- b) Designation : Principal/ Eco-club in- charge
- c) Since 2013

File Description	Document
Best practices in the Institutional web site	View Document
Any other relevant information	View Document

7.3 Institutional Distinctiveness

7.3.1 Portray the performance of the Institution in one area distinctive to its priority and thrust within 1000 words

Response:

Distinctive Feature - Healthcare Education and Research with Interdisciplinary and Integrative Approach

The primary focus of education and research at Jamia Hamdard is 'healthcare/biomedical education and research'. Jamia Hamdard is perhaps one of the few HEIs in India where modern medicine and traditional medicine flourish in sync. The institution was conceived as a seat of higher learning in Unani Medicine and other areas of knowledge by the Founder, Late Hakeem Abdul Hameed. The University strives to work with the vision of promoting study of modern and traditional medicine system which encompasses a holistic and integrative and interdisciplinary research in healthcare. Most of its School have one or more academic programmes and research thrust areas in the domain of healthcare.

Unani Medicine is one of the oldest traditional systems of medicine practiced in Indian subcontinent and has today become an integral part of the healthcare delivery system of India. Jamia Hamdard has been designated as institute of eminence for Unani Medicine by Ministry of AYUSH. Majeedia Unani Hospital is a teaching hospital associated with School of Unani Medical Education and Research to provide quality Unani medical education and training to the students. It is a 100 bedded hospital offering quality healthcare services at affordable cost and has specialty services in a wide range of illnesses right from hepatitis, diabetic foot, non-healing ulcers, musculoskeletal disorders, skin diseases to various life-style disorders.

The School of Pharmaceutical Education & Research is one of the most prestigious institutions of Pharmacy Education in India, has been ranked as No.1 among Pharmacy Institutions by the Ministry of Human Resources Development, Govt. of India for consecutive 4 years. Ph.D. in Pharmaceutical Medicine is a unique, first in country collaborative program being run in collaboration with Sun Pharmaceutical Industries Ltd. The school has collaborations both from academic and research institutions. Industry sponsored projects are also being executed for companies like Sun Pharma, Dabur Research Foundation, Jubilant Life Sciences, AIMIL Pharmaceuticals, Dolphin International, Fermish Clinical Technology, GBC, Beijing, China and Ultimax Health, USA etc. The school has a well-established central instrumentation facility (CIF) with modern and sophisticated instruments like cryogenic Transmission electron microscope (TEM), LC-MS, NMR, HPLC, HPTLC, DSC, UV-VIS spectrophotometer, FT-IR, AFM, etc. The school is research driven institution where most of the Departments are extensively involved in basic and advanced research activities, which is signatory of >2000 publications with > 20000 citations and >60 h index with various books and patents.

Several innovative research programmes are undertaken in collaboration with industry and research institutions. For example, innovative ideas in interdisciplinary sciences are the hallmark of drug discovery

where pharmaceutical sciences in collaboration with computer science a key role, especially in developing repurposed therapeutics.

Nursing is a profession within the healthcare sector, focused on the care of individuals, families, and communities. Rufaida College of Nursing, ever since its inception in 1983, besides offering UG and PG courses in nursing, also provides community outreach services for the underprivileged in the neighboring areas of the university and other areas in Delhi. The thrust area are: preventive health and health promotion, health education and awareness in Medical, Surgical, Obstetrics & Gynecology, Mental Health (Psychiatry), Community Health and Child Health Nursing.

Rehabilitation is a set of interventions designed to optimize functioning and reduce disability in individual with health conditions in interaction with their environment. It has two units: Occupational Therapy and Physiotherapy. In the Department of Rehabilitation sciences, the thrust areas are: neuro-rehabilitation; orthopedics rehabilitation; pediatric rehabilitation and early intervention; hand rehabilitation; cardio-pulmonary rehabilitation; mental Health and vocational rehabilitation and sport rehabilitation.

The Department of Paramedical Sciences was established in 2012 to train and provide skilled paramedical healthcare professionals. Students are trained in emergency trauma care, medical lab technologies, medical imaging techniques, operation theatre procedures, optometry, cardiology, medical records, and dialysis.

Hamdard Institute of Medical Sciences & Research (HIMSR) – the Medical School, is an ambitious project of Jamia Hamdard aimed at furthering its scope in the life sciences and health domains and providing quality healthcare at an affordable cost. HIMSR has been nationally recognized as an institute that demonstrates a high standard of undergraduate and postgraduate medical education. The institute is supported by Hakeem Abdul Hameed Centenary Hospital (HAHC) which is a 710 bedded, modern, state-of-the-art hospital.

The School of Chemical and Life Sciences enjoys national fame for its state-of-art infrastructure and cutting-edge research in the area of biochemical and life sciences. The faculty of the School is highly accomplished and is engaged in cutting-edge research in the field of biological sciences, biotechnology, and toxicology and clinical research.

The School of Management & Business Studies has research and academic programmes in the field of pharmaceutical and healthcare hospital management.

The Department of Molecular Medicine at School of Interdisciplinary Sciences & Technology (SIST) is a new addition with cutting edge research in the field of molecular medicine with target diseases of cancer, virus infections, and neurological disorders.

Thus, through its academic, research programmes and community outreach services, Jamia Hamdard focused its resources and efforts in the field of 'healthcare education and research'.

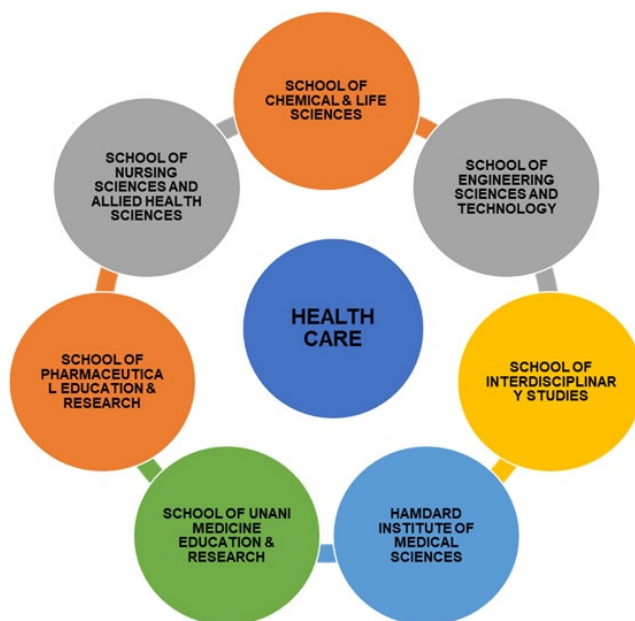

File Description	Document	
Any other relevant information	View Document	
Appropriate web in the Institutional website	View Document	

5. CONCLUSION

Additional Information :

Some of the salient accomplishments of Jamia Hamdard are highlighted below:

- Jamia Hamdard has established Research & Development Cell (RDC) as per UGC Guidelines (2022) and also implemented virtual research management through 'Research Management System'.
- Research excellence is demonstrated by high ratio of publication per faculty and citation per faculty. Based on excellence in research Jamia Hamdard was awarded mega funds under DST-PURSE and STUTI schemes. Currently, nine (09) Departments are supported under FST-FIST and five (05) Departments are supported under UGC-SAP programme. For excellence in research (publication and citation) 10 faculty and researchers have been placed in top 2% Scientists of the World in an analysis conducted by Stanford University (Indian Researchers in Stanford University's Top 2% Most Influential Scientists (Career Impact) (1960-2020) List- <https://insights2techinfo.com/indian-researchers-in-stanford-universitys-top-2-most-influential-scientists-list/>)
- Our Founder (Hakeem Abdul Hameed) always espoused mission of education of girls. He conceived and successfully implemented project of imparting Nursing Education to young women, especially from minority community with the establishment of Rufaida College of Nursing, which is one of the oldest Schools of Jamia Hamdard committed to imparting quality nursing education. Jamia Hamdard is proud to place on record that currently about 52% students in Jamia Hamdard are girls. Recently, we also established a girls' NCC Battalion to empower them and inculcate confidence in them so that they can contribute to nation building.
- In the Report of the Committee for Review of Existing Institutions Deemed to be Universities (2009) constituted by the Ministry of Human Resource Development (now - Ministry of Education) (Tandon Committee) placed Jamia Hamdard in Table I listing 38 Deemed Universities out of 129 justifying their continuation as "Deemed Universities".
- In the year 2019 it was included in the list of HEI for consideration of Institute of Eminence (HEI) by the Empowered Expert Committee constituted by the Government.
- Ministry of AYUSH has granted "Centre of Excellence" (CoE) in Unani Medicine (Pharmacognosy/Pharmacology) under AYURSWASTHA Yojna in March 2022.

Concluding Remarks :

"Quality is not act. It is a habit." ~Aristotle

The first cycle of NAAC-assessment and accreditation of Jamia Hamdard was performed in the year 2003, ever since, it has been accredited in two more cycles in the years 2011 and 2017. To our understanding, only few HEI have so far been accredited for the 4th cycle. Not only accreditation, Jamia Hamdard has participated in all the cycles of the ranking exercise conducted by the National Institutional Framework Ranking (NIRF). It has the distinction of being ranked No. 1 in Pharmacy for four consecutive cycles in NIRF (2019-222). The quality consciousness is percolated in a pyramid way – from top to bottom. All the heads of the institution have contributed to the quality enhancement and sustainability. IQAC has received the desired support to enable it to function as per the NAAC/UGC norms. Jamia Hamdard has a number of programmes under the purview of statutory councils – AICTE (engineering, management and pharmacy), INC (nursing), NMC/MCI (medicine), NCISM (Unani medicine), PCI (pharmacy) and RCI (rehabilitation science). Moreover, Jamia Hamdard

follows all the UGC Regulations in its true letter and spirit. Therefore, there is a continuous process of peer-reviewing and validation in place. In this SSR document we have attempted to showcase various quality metrics as per NAAC Manual (updated) and NAAC-SOPs. Like all other spheres of human activities, academic and research activities of Jamia Hamdard have also been affected for about two half years due to COVID-19 pandemic. Academic sessions, admission and examination process, research work, fee collection and functioning of departments were severely affected. We also lost some of colleagues and students in the deadly COVID-19 pandemic waves. It is our understanding that these facts will be taken into cognizance and factored. This SSR document is compilation, collation and presentation of our pursuit and rigour of providing the best resources and support to our students, teachers, and other staff. A large number of teachers who acted as Criteria Coordinators, Criteria Team Members, Nodal Officers and the University IT Team made sincere efforts to put their best foot forward. However, we welcome comments and suggestions to improve upon.

6.ANNEXURE

1.Metrics Level Deviations

Metric ID	Sub Questions and Answers before and after DVV Verification																				
1.1.2	<p>Percentage of Programmes where syllabus revision was carried out during the last five years.</p> <p>1.1.2.1. How many Programmes were revised out of total number of Programmes offered during the last five years Answer before DVV Verification : 81 Answer after DVV Verification: 81</p> <p>1.1.2.2. Number of all Programmes offered by the institution during the last five years. Answer before DVV Verification : 110 Answer after DVV Verification: 81</p> <p>Remark : DVV has made the changes as per 1.1</p>																				
1.2.2	<p>Percentage of Programmes in which Choice Based Credit System (CBCS) / elective course system has been implemented (Data for the latest completed academic year).</p> <p>1.2.2.1. Number of Programmes in which CBCS / Elective course system implemented. Answer before DVV Verification : 79 Answer after DVV Verification: 81</p> <p>Remark : DVV has made the changes as per 1.2</p>																				
1.3.3	<p>Average Percentage of students enrolled in the courses under 1.3.2 above.</p> <p>1.3.3.1. Number of students enrolled in value-added courses imparting transferable and life skills offered year-wise during the last five years. Answer before DVV Verification:</p> <table border="1"> <thead> <tr> <th>2021-22</th> <th>2020-21</th> <th>2019-20</th> <th>2018-19</th> <th>2017-18</th> </tr> </thead> <tbody> <tr> <td>7130</td> <td>7399</td> <td>6000</td> <td>5000</td> <td>4467</td> </tr> </tbody> </table> <p>Answer After DVV Verification :</p> <table border="1"> <thead> <tr> <th>2021-22</th> <th>2020-21</th> <th>2019-20</th> <th>2018-19</th> <th>2017-18</th> </tr> </thead> <tbody> <tr> <td>2995</td> <td>3445</td> <td>2707</td> <td>2410</td> <td>1902</td> </tr> </tbody> </table> <p>Remark : DVV has made the changes as per shared report by HEI.</p>	2021-22	2020-21	2019-20	2018-19	2017-18	7130	7399	6000	5000	4467	2021-22	2020-21	2019-20	2018-19	2017-18	2995	3445	2707	2410	1902
2021-22	2020-21	2019-20	2018-19	2017-18																	
7130	7399	6000	5000	4467																	
2021-22	2020-21	2019-20	2018-19	2017-18																	
2995	3445	2707	2410	1902																	
3.4.1	<p>The Institution ensures implementation of its stated Code of Ethics for research through the following:</p> <p>1. Inclusion of research ethics in the research methodology course work</p> <p>2. Presence of Ethics committee</p>																				

3. Plagiarism check through software**4. Research Advisory Committee**

Answer before DVV Verification : A. All of the above

Answer After DVV Verification: B. 3 of the above

Remark : DVV has select B. 3 of the above as per shared report by HEI.

3.4.6 Number of books and chapters in edited volumes/books published and papers published in national/ international conference proceedings per teacher during last five years**3.4.6.1. Total number of books and chapters in edited volumes/books published and papers in national/ international conference proceedings year-wise during last five years**

Answer before DVV Verification:

2021-22	2020-21	2019-20	2018-19	2017-18
106	306	252	192	207

Answer After DVV Verification :

2021-22	2020-21	2019-20	2018-19	2017-18
106	306	252	192	207

3.6.3 Number of extension and outreach programs conducted by the institution through NSS/NCC, Government and Government recognised bodies during the last five years**3.6.3.1. Number of extension and outreach programs conducted by the institution those through NSS/NCC, Government and Government recognised bodies during the last five years**

Answer before DVV Verification:

2021-22	2020-21	2019-20	2018-19	2017-18
21	79	47	30	34

Answer After DVV Verification :

2021-22	2020-21	2019-20	2018-19	2017-18
15	61	41	24	28

4.1.4 Average percentage of expenditure for infrastructure augmentation excluding salary during the last five years (INR in Lakhs)**4.1.4.1. Expenditure for infrastructure augmentation, excluding salary during the last five years (INR in lakhs)**

Answer before DVV Verification:

2021-22	2020-21	2019-20	2018-19	2017-18
184	414	392	666	1103

Answer After DVV Verification :

2021-22	2020-21	2019-20	2018-19	2017-18
184.00	414.00	360.26	631.66	1091.42

Remark : DVV has converted the value into lakhs.

4.2.3 Average annual expenditure for purchase of books/ e-books and subscription to journals/e-journals during the last five years (INR in Lakhs)

4.2.3.1. Annual expenditure for the purchase of books and journals including e-journals year-wise during last five years (INR in Lakhs)

Answer before DVV Verification:

2021-22	2020-21	2019-20	2018-19	2017-18
35.47	13.77	33.95	74.28	40.92

Answer After DVV Verification :

2021-22	2020-21	2019-20	2018-19	2017-18
35.47	13.77	33.95	50.03	12.7

4.4.1 Average percentage expenditure incurred on maintenance of physical facilities and academic support facilities excluding salary component during the last five years

4.4.1.1. Expenditure incurred on maintenance of infrastructure (physical facilities and academic support facilities) excluding salary component year-wise during the last five years (INR in lakhs)

Answer before DVV Verification:

2021-22	2020-21	2019-20	2018-19	2017-18
1589	2399	2612	3434	2544

Answer After DVV Verification :

2021-22	2020-21	2019-20	2018-19	2017-18
1589.00	2399.00	2612.00	3434.00	2544.00

Remark : DVV has converted the value into lakhs only.

5.2.2 Average percentage of placement of outgoing students during the last five years

5.2.2.1. Number of outgoing students placed year - wise during the last five years.

Answer before DVV Verification:

2021-22	2020-21	2019-20	2018-19	2017-18

133	862	435	371	514
-----	-----	-----	-----	-----

Answer After DVV Verification :

2021-22	2020-21	2019-20	2018-19	2017-18
133	757	392	348	489

5.2.3 Percentage of student progression to higher education (previous graduating batch).

5.2.3.1. Number of outgoing student progressing to higher education.

Answer before DVV Verification : 800

Answer after DVV Verification: 747

5.3.1 Number of awards / medals won by students for outstanding performance in sports / cultural activities at inter-university / state / national / international events (award for a team event should be counted as one) during the last five years.

5.3.1.1. Number of awards/medals won by students for outstanding performance in sports / cultural activities at inter-university / state / national / international events (award for a team event should be counted as one) year - wise during the last five years.

Answer before DVV Verification:

2021-22	2020-21	2019-20	2018-19	2017-18
8	11	10	6	5

Answer After DVV Verification :

2021-22	2020-21	2019-20	2018-19	2017-18
5	8	8	4	3

6.3.4 Average percentage of teachers undergoing online/ face-to-face Faculty Development Programmes (FDP)during the last five years (Professional Development Programmes, Orientation / Induction Programmes, Refresher Course, Short Term Course).

6.3.4.1. Total number of teachers attending professional development Programmes, viz., Orientation Programme, Refresher Course, Short Term Course, Faculty Development Programmes year wise during last five years

Answer before DVV Verification:

2021-22	2020-21	2019-20	2018-19	2017-18
38	21	42	70	33

Answer After DVV Verification :

2021-22	2020-21	2019-20	2018-19	2017-18
27	21	42	70	31

6.4.2 **Funds / Grants received from government bodies during the last five years for development and maintenance of infrastructure (not covered under Criteria III and V) (INR in Lakhs).**

6.4.2.1. *Total Funds / Grants received from government bodies for development and maintenance of infrastructure (not covered under Criteria III and V) year wise during the last five years (INR in Lakhs).*

Answer before DVV Verification:

2021-22	2020-21	2019-20	2018-19	2017-18
810	800	800	800	872

Answer After DVV Verification :

2021-22	2020-21	2019-20	2018-19	2017-18
810.00	800.00	800.00	800.00	872.00

Remark : DVV has converted the value into lakhs.

6.4.3 **Funds / Grants received from non-government bodies, individuals, philanthropists during the last five years (not covered in Criterion III and V) (INR in Lakhs)**

6.4.3.1. Total Grants received from non-government bodies, individuals, Philanthropers year wise during the last five years (INR in Lakhs)

Answer before DVV Verification:

2021-22	2020-21	2019-20	2018-19	2017-18
809.04	1045.05	1077.39	5322.42	1634

Answer After DVV Verification :

2021-22	2020-21	2019-20	2018-19	2017-18
809.04	1045.05	1077.39	5322.42	1634.00

Remark : DVV has converted the value into lakhs.

2.Extended Profile Deviations

ID	Extended Questions										
1.1	<p>Number of programs offered year-wise for last five years</p> <p>Answer before DVV Verification:</p> <table border="1"> <thead> <tr> <th>2021-22</th> <th>2020-21</th> <th>2019-20</th> <th>2018-19</th> <th>2017-18</th> </tr> </thead> <tbody> <tr> <td>110</td> <td>108</td> <td>94</td> <td>94</td> <td>77</td> </tr> </tbody> </table> <p>Answer After DVV Verification:</p>	2021-22	2020-21	2019-20	2018-19	2017-18	110	108	94	94	77
2021-22	2020-21	2019-20	2018-19	2017-18							
110	108	94	94	77							

2021-22	2020-21	2019-20	2018-19	2017-18
81	108	94	94	77

2.5 **Total Expenditure excluding salary year-wise during last five years (INR in Lakhs)**

Answer before DVV Verification:

2021-22	2020-21	2019-20	2018-19	2017-18
2266	5959	6535	7631	6908

Answer After DVV Verification:

2021-22	2020-21	2019-20	2018-19	2017-18
2266.00	5959.00	6535.00	7631.00	6908.00



3.1.1
Minutes of Governing
Council/Syndicate/Board of Management
related to research promotion policy
adoption